

TECHNICAL DATA SHEET

DESCRIPTION

Our C24 Precast Half Hanger are interior form hangers that consist of a U shape end clip welded to a shaped wire strut

APPLICATION

C24 are designed and developed for use in wide precast concrete girders. They are used in all types of precast concrete bridge girders and beams to support temporary constructed formwork. Precast hangers are installed by the precaster during the girder production process with predetermined centers prior to installment provided by the bridge contractor.

PRODUCT SPECIFICATION

- Type C for concrete beam
- 2 to 1 safety factor
- 6,000lb. Safe Working Load
- Available; Epoxy Coated, Hot Dip Galvanize and Plain

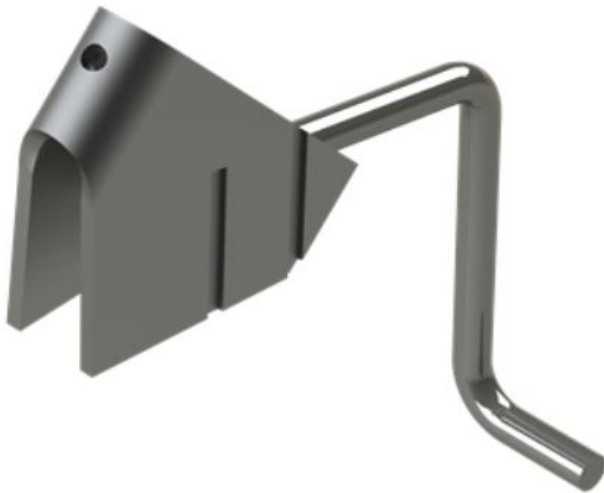

FEATURES

- Shaped strut configuration
- 45° end clip position
- Bearing Plate, per request

HOW TO SPECIFY

Precast Half Hangers shall be supported as manufactured by Dayton Superior Corporation.

Technical Data

Precast Half Hanger Embeds

| Type | SWL (lbs) | Dia. Bolt | Factor of Safety |
|-------|-----------|-----------|------------------|
| 4-APR | 6,000 | 1/2" | 2 to 1 |

INSTALLATION

1. Care must be exercised by the precaster to install these hangers so there will be a 1/8" clearance between the edge of beam and 1/2" coil bolt.

INSTALLATION

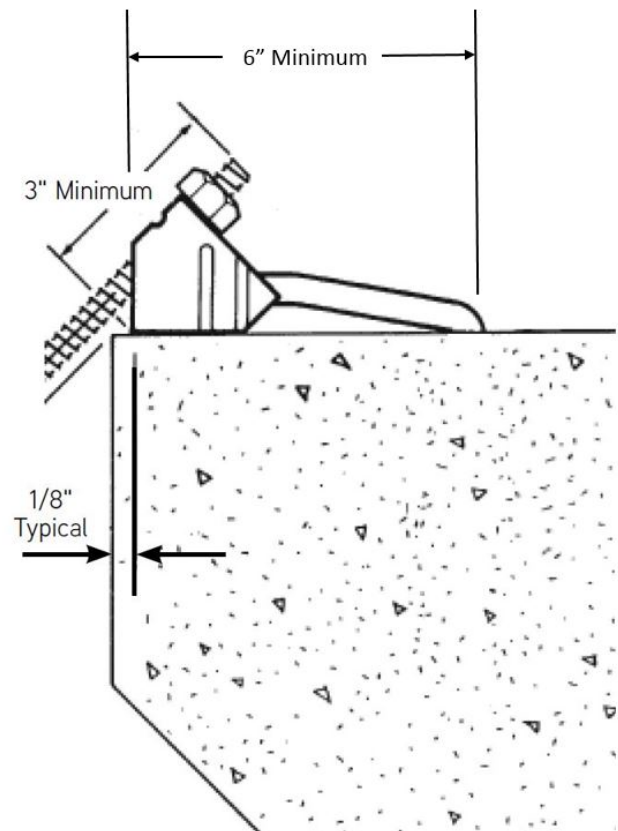

RELATED PRODUCTS

- B12 Continuous Coil Threaded Rod
- B13 Coil Nut
- C25 Pres-Steel Adjustable Half Hanger
- C60 Pres-Steel Hanger
- C63 Pres-Steel Hook Half Hanger
- C65 Adjustable Joist Hanger
- C68 Ty-Down Half Hanger

HOW TO ORDER

- Specify:
 1. Quantity
 2. Name
 3. Strut Length
 4. Bearing Plate per request

TECHNICAL DATA SHEET

ORDERING INFORMATION**TYPE P PRECAST HALF HANGER EMBEDS**

| Product Code | Description | Weight |
|--------------|------------------------------------|---------|
| 146674 | 4-APR HDGAL 17" X 4" X 2" X 45 DEG | LB |
| 146675 | 4-APR PLAIN 17" X 4" X 2" X 45 DEG | LB |
| 105580 | 4-APR 6" X 4" X 2" X 45 DEG | 0.81 LB |
| 105579 | 4-APR 12" X 4" X 2" X 45 DEG | 1.24 LB |

MANUFACTURER

Dayton Superior Corporation
1125 Byers Road
Miamisburg, OH 45342
Customer Service: 888-977-9600
Technical Services: 877-266-7732
Website: www.daytonsuperior.com

WARRANTY (ACCESSORIES)

Limited Warranty. Dayton warrants, for a period of 60 days from the date of shipment (three years from the date of shipment in the case of formwork, excluding any consumable Products included with such formwork), that Products and any associated application drawings and engineering services provided by Dayton ("Ancillary Services") will be free from defects in material and workmanship and, in the case of custom designed formwork, that the formwork will meet the specifications set forth in the design drawings approved by Dayton and Customer. Any claim under this warranty must be made in writing within such warranty period. If any Product and/or Ancillary Service covered by a timely claim are found to be defective, Dayton will, within a reasonable time, make any necessary repairs or corrections or, at Dayton's option, replace the Product. Unless pre-authorized by Dayton in writing, Dayton will not accept any charges for correcting defects or accept the return of any Product. This warranty will not apply to any Products that have been subjected to misuse, neglect, storage damage, misapplication, accident or any other damage caused by any person other than Dayton, or that have not been maintained in accordance with Dayton's specifications. THIS LIMITED WARRANTY IS IN LIEU OF ALL OTHER WARRANTIES AS TO THE PRODUCTS AND ANCILLARY SERVICES. DAYTON MAKES NO OTHER WARRANTIES OR GUARANTEES, EXPRESS OR IMPLIED, INCLUDING ANY WARRANTY OF MERCHANTABILITY, FITNESS FOR A PARTICULAR PURPOSE OR OTHERWISE. THE REMEDIES SET FORTH IN THIS SECTION ARE CUSTOMER'S EXCLUSIVE REMEDY FOR BREACH OF WARRANTY.