

TECHNICAL DATA SHEET

DESCRIPTION

B13 Coil Nuts are manufactured from high strength steel.

APPLICATION

B13 Coil Nuts are used with B12 Coil Rod in many applications and used in the field.

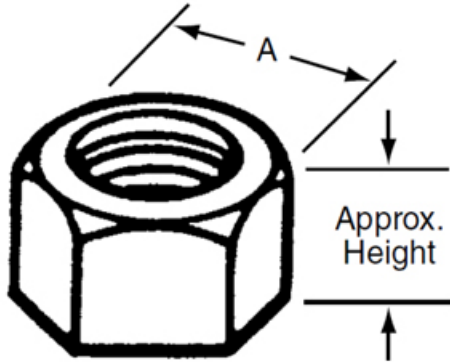

FEATURES

- These nuts are right hand threads.
- B13 Coil Nuts are available in 1/2" to 1-1/2" diameters.
- Two B13 Coil Nuts are required to develop B12 Coil Rod Ultimate Load.

TECHNICAL DATA

Dia.	Approx. Height	Width Across Flats A	Safe Working Load (lbs.)	
			Using One B13 Nut	Using Two B13 Nuts or One B25 Heavy Nut
1/2"	7/16"	7/8"	6,000	9,000
3/4"	5/8"	1-1/8"	9,000	18,000
1"	1"	1-5/8"	24,000	38,000
1-1/4"	1-1/4"	2"	36,000	56,000
1-1/2"	1-1/2"	2-3/8"	47,500	68,000

SWL provides a factor of safety of approximately 2 to 1

RELATED PRODUCTS

- B25 Heavy Coil Nuts
- B12 Coil Rod
- B11 Flat Washer

HOW TO ORDER

Specify: (1) quantity, (2) name, (3) bolt diameter.
Example: 200 pcs. B13 Coil Nut, 3/4".

Additional sizes and domestic made are available as Made to Order items.

ORDERING INFORMATION

COIL NUTS RIGHT HAND THREAD

Product Code	Description	Weight
45600	1/2" PLAIN - 12,000 LBS ULTIMATE LOAD	0.06 LB
100515	5/8" PLAIN - 16,000 LBS ULTIMATE LOAD	0.11 LB
45700	3/4" PLAIN - 18,000 LBS ULTIMATE LOAD	0.11 LB
45702	3/4" PLAIN - 24,000 LBS ULTIMATE LOAD	0.18 LB
100520	7/8" PLAIN - 30,000 LBS ULTIMATE LOAD	0.28 LB
45800	1" PLAIN - 48,000 LBS ULTIMATE LOAD	0.40 LB
45900	1-1/4" PLAIN	0.76 LB
45910	1-1/2" PLAIN	1.51 LB
76161	1/2" ELECTRO GALV. - 12,000 LBS ULTIMATE LOAD	0.07 LB
76187	3/4" ELECTRO GALV. - 18,000 LBS ULTIMATE LOAD	0.12 LB
76206	1" ELECTRO GALV. - 48,000 LBS ULTIMATE LOAD	0.41 LB
121044	1/2" T304 SS - 18,000 LBS ULTIMATE LOAD	0.06 LB
126746	3/4" T304 SS - 35,000 LBS ULTIMATE LOAD	0.13 LB
114360	1" T304 SS - 55,000 LBS ULTIMATE LOAD	0.41 LB
114370	1-1/4" T304 SS - 85,000 LBS ULTIMATE LOAD	0.521 LB

COIL NUTS RIGHT HAND THREAD - CANADA ONLY

Product Code	Description	Weight
700127	CANADA ONLY; 1/2" PLAIN	0.08 LB
700129	CANADA ONLY; 3/4" PLAIN	0.22 LB

MANUFACTURER

Dayton Superior Corporation
1125 Byers Road
Miamisburg, OH 45342
Customer Service: 888-977-9600
Technical Services: 877-266-7732
Website: www.daytonsuperior.com

TECHNICAL DATA SHEET

WARRANTY (ACCESSORIES)

Limited Warranty. Dayton warrants, for a period of 60 days from the date of shipment (three years from the date of shipment in the case of formwork, excluding any consumable Products included with such formwork), that Products and any associated application drawings and engineering services provided by Dayton ("Ancillary Services") will be free from defects in material and workmanship and, in the case of custom designed formwork, that the formwork will meet the specifications set forth in the design drawings approved by Dayton and Customer. Any claim under this warranty must be made in writing within such warranty period. If any Product and/or Ancillary Service covered by a timely claim are found to be defective, Dayton will, within a reasonable time, make any necessary repairs or corrections or, at Dayton's option, replace the Product. Unless pre-authorized by Dayton in writing, Dayton will not accept any charges for correcting defects or accept the return of any Product. This warranty will not apply to any Products that have been subjected to misuse, neglect, storage damage, misapplication, accident or any other damage caused by any person other than Dayton, or that have not been maintained in accordance with Dayton's specifications. THIS LIMITED WARRANTY IS IN LIEU OF ALL OTHER WARRANTIES AS TO THE PRODUCTS AND ANCILLARY SERVICES. DAYTON MAKES NO OTHER WARRANTIES OR GUARANTEES, EXPRESS OR IMPLIED, INCLUDING ANY WARRANTY OF MERCHANTABILITY, FITNESS FOR A PARTICULAR PURPOSE OR OTHERWISE. THE REMEDIES SET FORTH IN THIS SECTION ARE CUSTOMER'S EXCLUSIVE REMEDY FOR BREACH OF WARRANTY.