

C53 2x6 Guard Rail Receptacle

The C53 Guard Rail Receptacle is designed to allow the easy installation of an OSHA required guard rail post on the exterior formwork of a bridge deck.

The C53 receptacle slips over the end of the 2x6 (flat) nailer that is attached to and extends beyond the end of a bridge overhang bracket's horizontal member. The C53 receptacle is nailed to the 2x6 flat nailer, using two 16d double headed nails, one on each side, in the provided hole.

This receptacle readily accepts a 2x6 guard rail post.

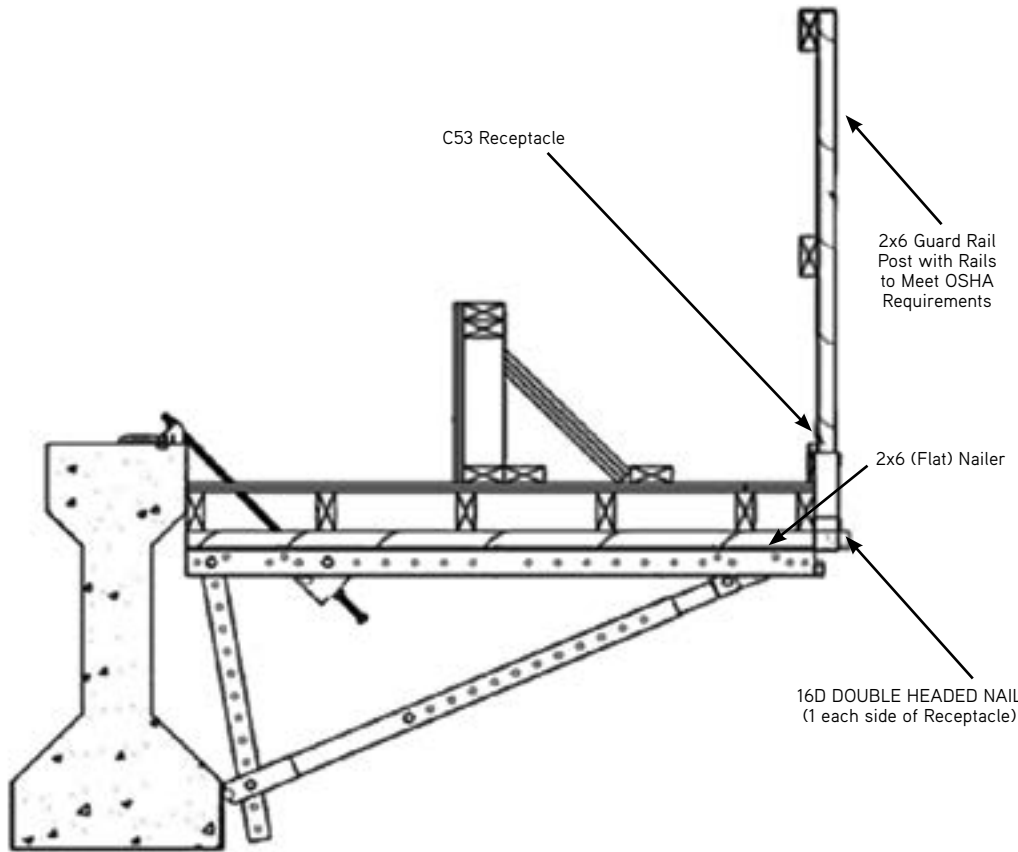

Typical Section Through Overhang
Actual Overhang Conditions May Vary

Bridge Overhang Brackets

To Order:
Specify: (1) quantity, (2) name.

Example:
600 pcs. C53 Bridge Guard Rail Receptacle.