

MultiDrain Systems, Inc.

Manufacturers of Pre-engineered Trench Drain Systems

EconoDrain[®] & EconoDrain PT-2[™] INSTALLATION INSTRUCTIONS

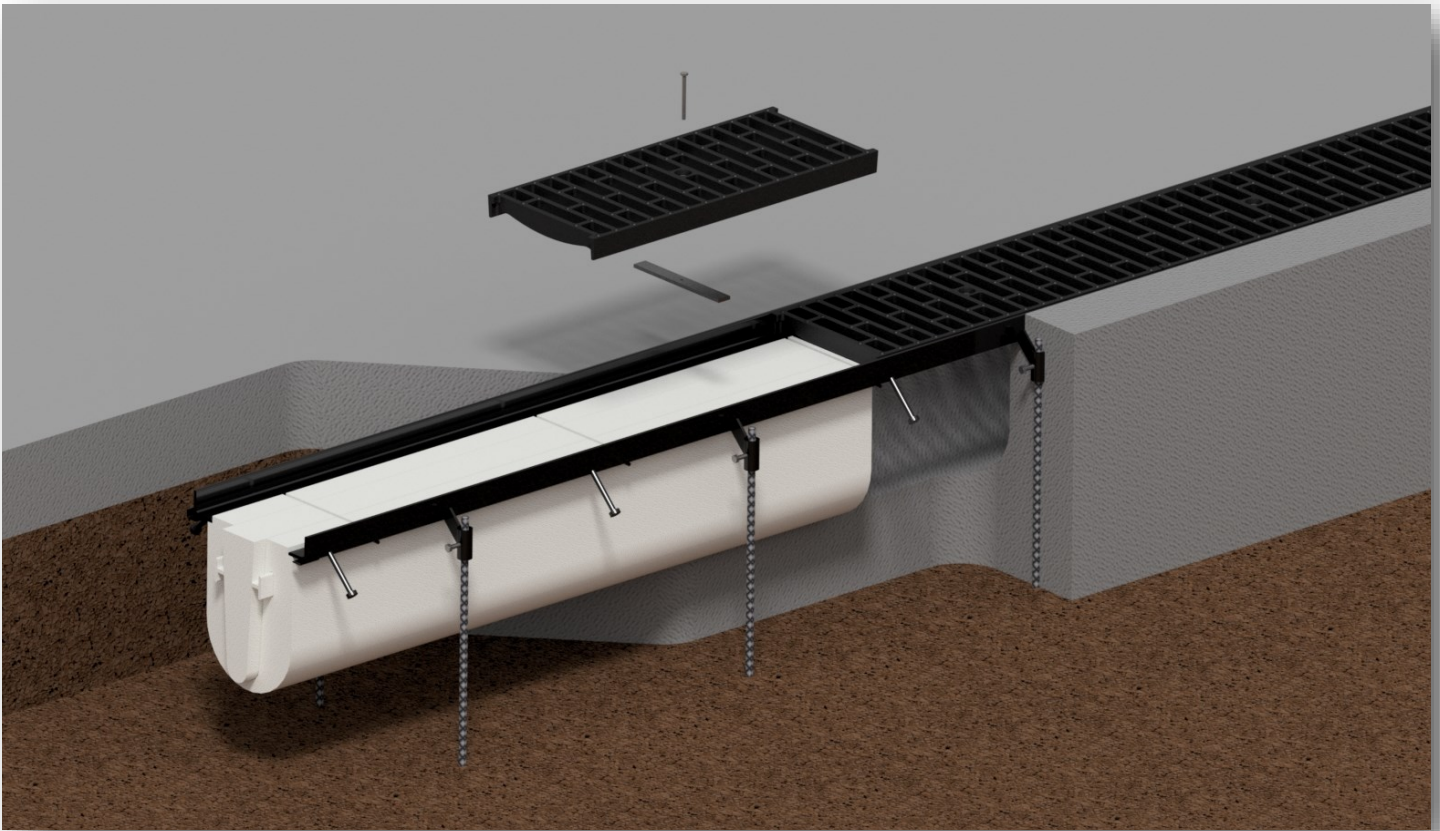

Surface Drainage Technology & Solutions

EconoDrain[®] • EconoDrain PT-2[™] • EconoDrain DG-4[™] • Alfa Channel[®] • Alfa Slot[®] • MultiDrain[®]

MultiDrain[®]
We Drain Your Site, Not Your Budget!

EconoDrain[®]
www.multidrainsystems.com

EXAMINE GOODS BEFORE FREIGHT COMPANY LEAVES!

LOST OR DAMAGED GOODS

YOU MUST THOROUGHLY INSPECT THIS SHIPMENT AT THE TIME IT IS RECEIVED!!!!!!!!!!!!

This material was carefully counted, packaged, and properly loaded for shipment when accepted by the carrier.

In the event of any loss or damage, **the delivery receipt MUST BE SIGNED AND NOTED AS SUCH.**

You must notify your freight agent at once and request him/her to make an inspection report. This is absolutely necessary. If not done, the transportation company will not entertain any claim for loss or damage. Your acceptance of a shipment that is short or in damaged condition without proper notation is done at your own risk.

After an inspection report and claim have been submitted to the carrier, you **MUST RETAIN the material for possible carrier pick up, prior to the payment of the claim.**

This material was shipped **FOB** Shipping Point. Contrary to popular belief, **FOB (FREE on Board)** does not determine who pays the freight. **FOB** is the point where the title of the goods passes from seller to buyer. The carrier now acts as an agent for the buyer. In accordance with common law, the responsibility of the seller ceases at the time the carrier picks up the freight.

It is the legal duty of the consignee or the owner to accept damaged freight. Common law is quite clear on this subject. The fact that goods are damaged during transportation through causes for which the carrier is responsible does not justify the consignee in refusing to receive them; but he must accept the good, effect repairs and hold the carrier liable for the actual extent of the damage.

NOTES: Claims for loss or damage must not be deducted from our invoice, nor payment withheld while awaiting adjustment of such claim.

WE ARE WILLING TO ASSIST YOU IN EVERY POSSIBLE MANNER IN COLLECTING CLAIMS FOR LOSS OR DAMAGE IN TRANSIT, BUT THIS DOES NOT MAKE US RESPONSIBLE FOR COLLECTION OF CLAIMS OR REPLACEMENT OF THE MATERIAL.

Thank you for including EconoDrain[®] in your project.

We are confident that you will find EconoDrain to be the fastest and most economical trench drain system to install.

EconoDrain provides a versatile and durable trench drain or pathway for a wide variety of applications. It is available in standard widths of 4 -1/2", 6", 8", 10", 12", 15", 18" and 24". The standard form length is 8' (96") with 4' (48") and 2' (24") lengths available to meet specific project requirements.

Standard EconoDrain trench slope is 0.5% with neutral and custom slopes available as options. Long continuously sloped trench runs are enabled without costly special components.

EconoDrain can be custom engineered to meet your specific project specifications.

Do not hesitate to contact your local EconoDrain distributor or our customer service at (800) 433-1119 for any questions or comments concerning EconoDrain products or their installation.

Again, thank you for using EconoDrain.

Before You Get Started

READ THE ENTIRE INSTALLATION BOOKLET BEFORE YOU START

This will help prevent costly mistakes later!

In preparation to install EconoDrain, please make sure you have the following tools and equipment available:

- #4 or #5 Anchoring Rebar (**Anchoring Rebar Supplied by Others**)
- Hammer to drive rebar & flat stakes into Sub-Base
- String-line & flat stakes
- Bubble level
- Transit
- Duct tape
- EPS foam form release & Applicator Brush
- 10 to 12 - 2" x 10" x 12" wooden blocks
- Tie wire
- Concrete Finger (Probe) Vibrator
- Pipe for trench outlet
- 4" Hand Grinder with metal cut-off blade
- 1/2" Socket Wrench

Everything necessary for a successful EconoDrain installation will be included in your product shipment (dependent upon order variables). Typically we supply the EPS Foam Forms, Frame Assemblies or Frame Rail and Bolt-In-Place Rail Spacer Bars, Grates, Form Release, End Plates, Locking Devices and Components.

Rebar required for installation should be obtained locally (By Others), however, this can be supplied with the shipment. Rebar is not a part of the EconoDrain quotation unless spelled out or specified on the quotation.

TYPICAL ECONODRAIN SECTION

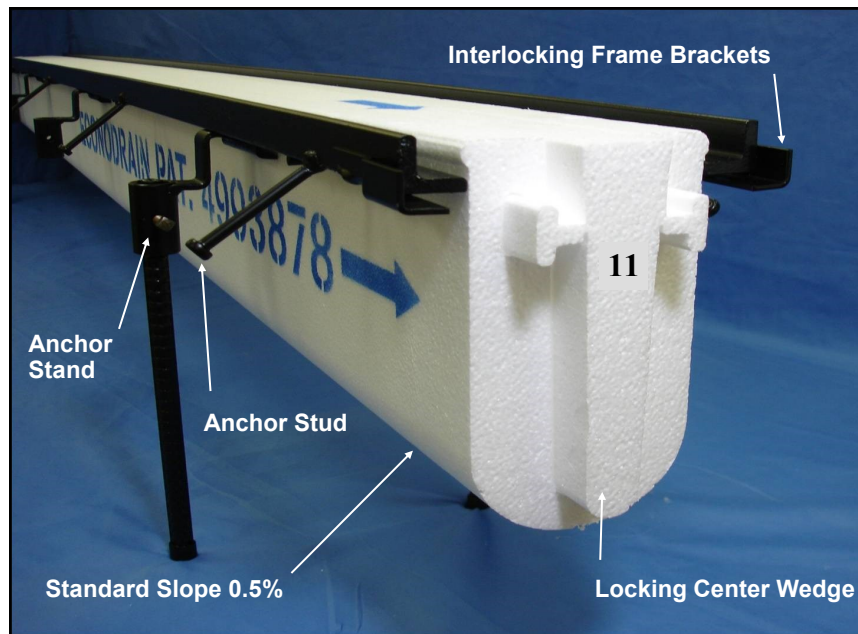

Grate Frame / Rail Op-

EconoDrain Series	#4	#6	#8	#10	#12	#15	#18	#24	#8 PT-2	#12 PT-2
Welded Rod Frame Spacer	Only Option	Standard	Standard	Not Available	Standard	Not Available	Not Available	Not Available	Not Available	Not Available
Bolt-in-Place Rail Spacer Bar	Not Available	Option	Option	Only Option	Option	Only Option	Only Option	Only Option	Only Option	Only Option
FRAME RAIL OPTIONS										
Black, Polyester Powder Coating	Standard	Standard	Standard	Standard	Standard	Standard	Standard	Standard	Standard	Standard
Galvanized - Hot Dipped	Option	Option	Option	Option	Option	Option	Option	Option	Option	Option
Stainless Steel	Option	Option	Option	Option	Option	Option	Option	Option	Option	Option

- Frame Assembly: Welded Spacer Rod Frame Assembly or Bolt-In-Place Spacer Bar Rail Assembly (See Page 6 for Details)
- Interlocking Frame Brackets
- Anchor Stand With Hex Bolt
- Anchor Stud
- EPS Form With Arrow Showing the Direction of Slope
- EPS Form Locking Center Wedge With Form ID Number
- Standard Slope is 0.5% (Can be Customized)
- #4 or #5 Anchoring Rebar (SUPPLIED BY OTHERS)
- Radius Bottom (Can be Customized or Square / Flat Bottom Available)

Step 1: Apply Form Release to EPS Forms

MUST APPLY FORM RELEASE TO EPS FORMS PRIOR TO INSTALLING IN FRAME.

The EPS forms should be coated with EconoDrain form release before any other steps allowing sufficient drying time prior to assembly.

Do not coat the first three inches (3") on either end of the EPS forms; since joint duct tape will be placed here in Step #12.

While a brush is recommended for applying Form Release, a hand sprayer may be used. Assure the Form Release is mixed regularly to prevent the release agent from falling out of liquid suspension.

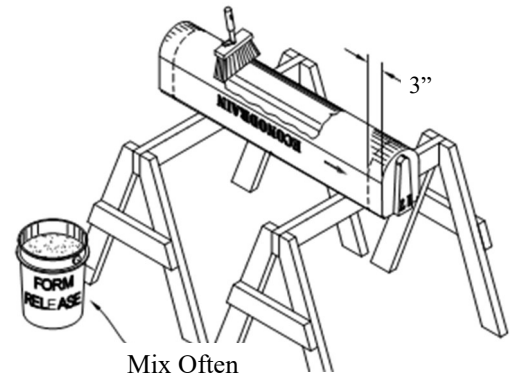

Mix Often

WARNING: Former Release is not intended for storage or material application under freezing conditions. Exposure of containers to freezing temperatures can cause irreversible damage, rendering product unusable.

CAUTION: Do not use Petroleum Base Form Release - It will damage the EPS Forms!

Step 2: PREPARE EXCAVATION AND SET ALIGNMENT GUIDE

A trench shall be excavated a minimum of 12" wider than the overall width of the steel frame (6" minimum on each side) and a minimum of 6" deeper than the overall depth of the EconoDrain EPS Form. Structural Engineer must determine the concrete thickness and specifications. For Depths, Refer to Table on Page 19.

The above guidelines are MINIMUM dimensions which may be increased to meet structural requirements of concrete matrix design. The local Structural Engineer will determine the concrete's overall thickness and reinforcement geometry.

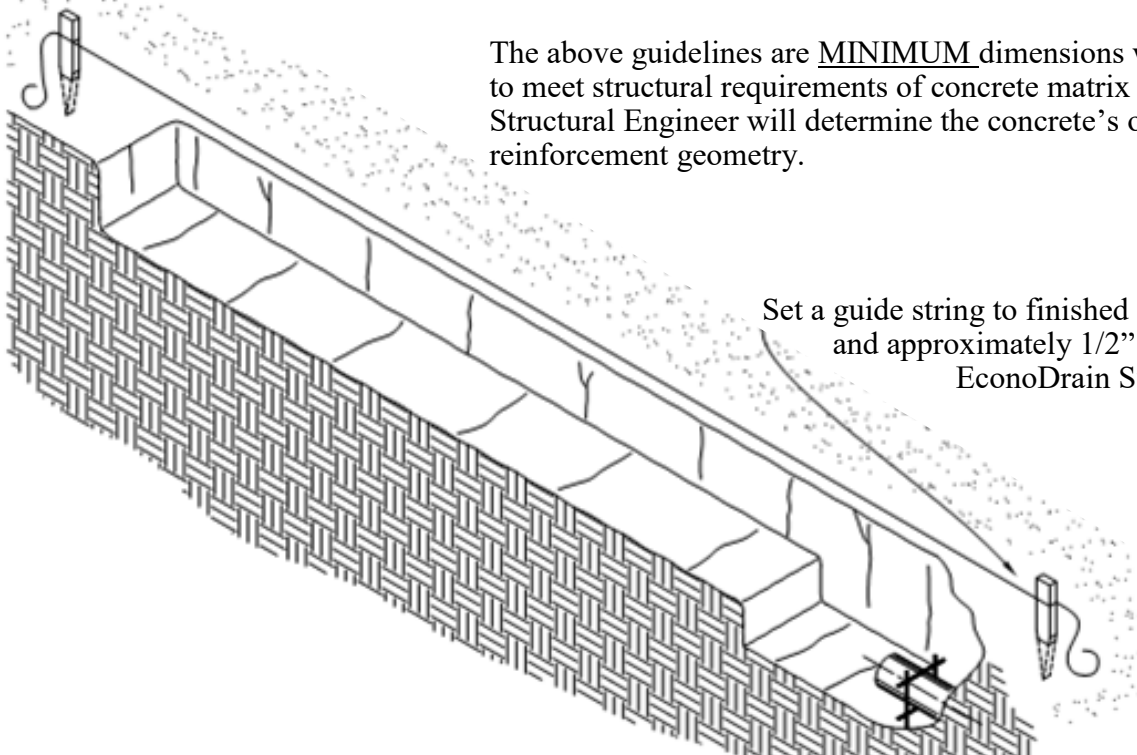

Set a guide string to finished concrete slab elevation and approximately 1/2" outside one side of the EconoDrain System frame assembly.

The EconoDrain System typically incorporates slope within the trench run length flowing from the shallow end to the deeper end. Slope excavation accordingly (See Step 2 Above).

Step 3: Assemble the EPS Forms to the Welded Frame Assembly

NOTE: IF FRAME RAILS AND BOLT-IN-PLACE SPACER BAR IS USED SEE PAGE 7.

The EconoDrain EPS Form Center Wedge and Outer Section are shipped assembled, but must be properly aligned upon arrival at the jobsite. Before assembling to frames, align the EPS Form Outer Section slots to those in the Center Wedge protruding approximately 1" on the downstream end of the EPS Form. Downstream (deeper end) is indicated by an arrow stenciled on the side of the EPS Form and by Form Numbers placed on the projecting end of the Center Wedge.

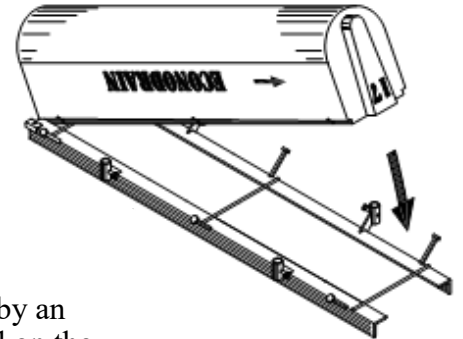

Attach the EPS Form to the frame assembly by aligning the Spacer Rod with the slots in the EPS Form and carefully press the EPS Form onto the Rods, press slowly with equal pressure to prevent damage to the EPS Form until the Spacer Rods are seated at the bottom of the EPS form slots.

Step 4: Beginning the Installation

ward until the installation is complete. Set Catch Basin first (if used). Refer to Steps 6 & 7 for Typical Catch Basin Installation.

Begin all installations at the trench outlet or downstream end and work back-

See Page 15 for use of Intersection Kits for forming left and right L's, T,s and Four-way intersections.

Installation of deeper EPS Forms (greater than 15" deep) require stabilization of the Form during concreting to prevent the EPS Form bottom from being moved from side to side by the concrete. Refer to Step 14 on page 11 for guidance on this procedure.

Step 5: Layout EconoDrain Assembly in Desired Installation Sequence

Prior to actual installation, lay out EconoDrain assemblies in numerical sequence with the highest number (deepest section) at the discharge point with all EPS Form arrows pointing toward the discharge point.

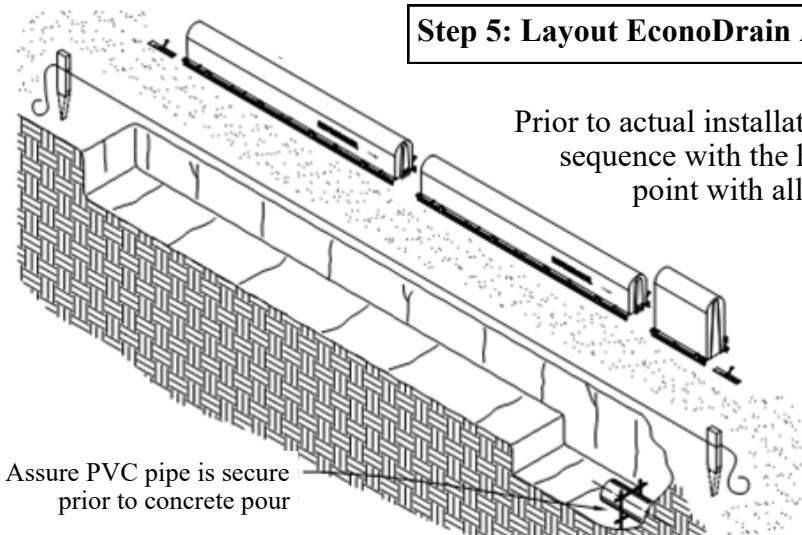

Assure PVC pipe is secure prior to concrete pour

ECONODRAIN
3A: OPTIONAL BOLT-IN-PLACE SPACER BAR & FRAME ASSEMBLY

NOTE: FIELD ASSEMBLED

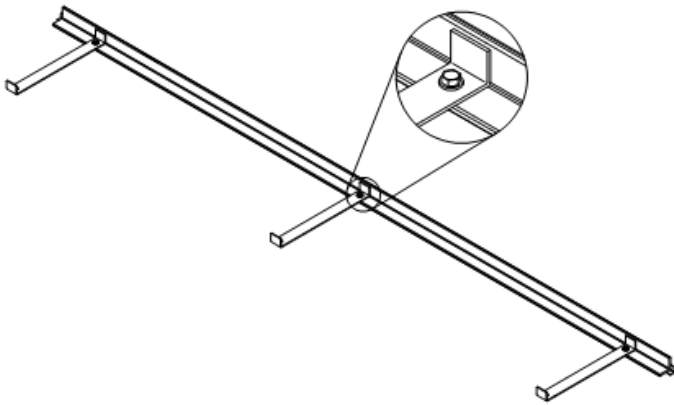

STEP 1

Bolt 3 Rail Spacer Bars to one side of the Frame Rail.

Spacer Bar Bolts; 5/16" - #18 x 3/4"

Socket Size: 1/2"

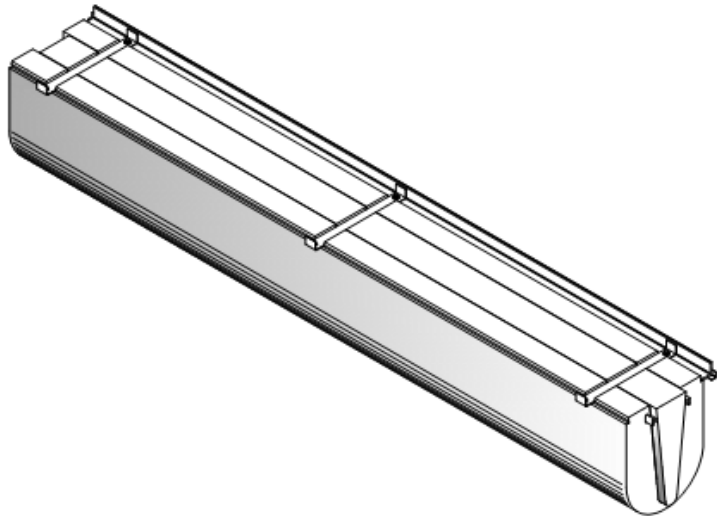

STEP 2

Place the EPS Foam Form against the Frame Rail aligning the slots in the EPS Form and the Rail Spacers.

MUST APPLY FORM RELEASE TO EPS FORMS PRIOR TO INSTALLING IN FRAME RAIL.

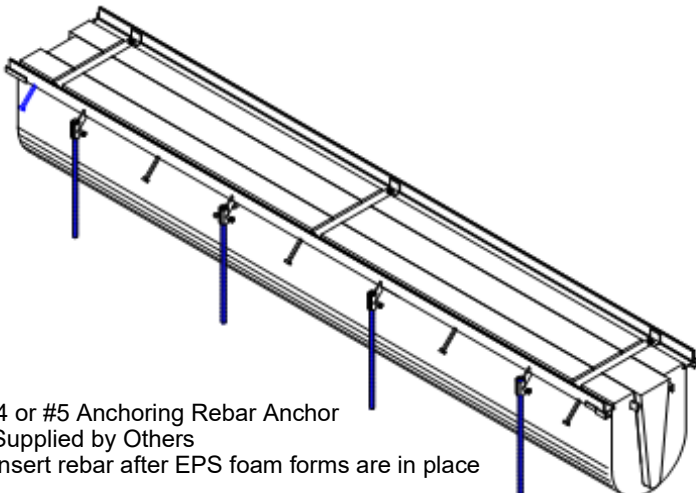

STEP 3

Place parallel Rail against the EPS Foam Form aligning the bolt hole in the Frame Rail with the hole in the Spacer Bar and bolt-in-place.

Left and right Rail shall be affixed together with Bolt-In-Place Rail Spacer Bars to assure proper symmetry and planar accuracy.

#4 or #5 Anchoring Rebar Anchor

*Supplied by Others

*Insert rebar after EPS foam forms are in place

To Proceed See Step 4 on Page 6.

Step 6: Typical Installation of Catch Basin - 24" x 24"

Assure top is level with finished slab elevation

Assure top end of rebar is flush with top of Anchor Stand

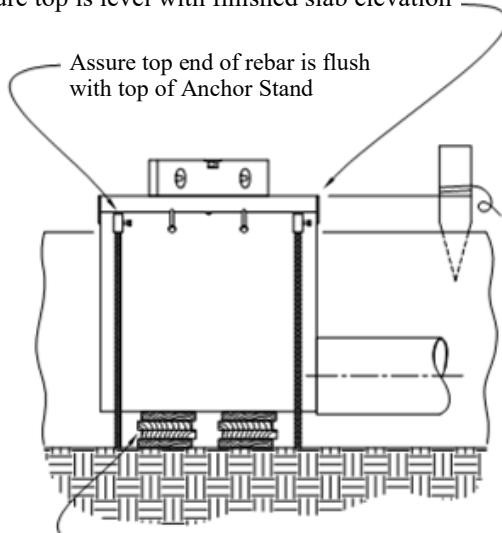

Remove wood blocks prior to concrete pour

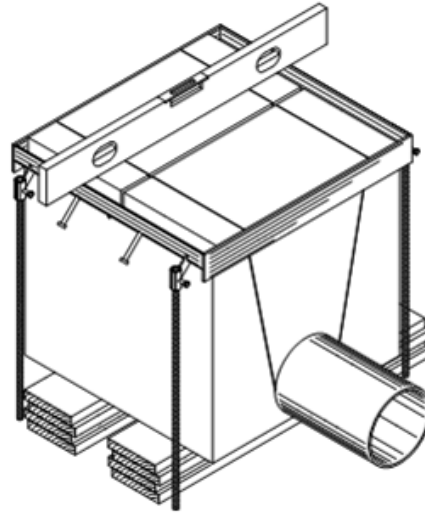

Step 7: Installation of In-Line Catch Basin

Assure top is level with finished slab elevation

Attach the Frame End Plate To the Frame Assembly

Assure top end of rebar is flush with top of Anchor Stand

Remove wood blocks prior to concrete pour

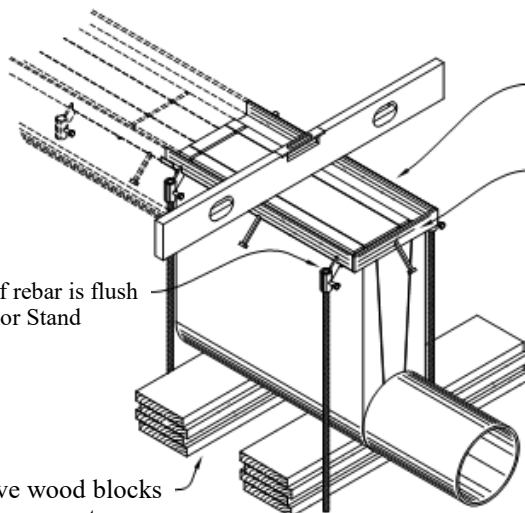

Step 8: Installation of EconoDrain EPS Trench Forming Assembly

Install the outlet Trench Form or Catch Basin component first.

Use wooden blocks to support the EconoDrain assembly above the floor of the trench excavation and approximately 1” below the desired finished elevation.

Insert #4 (or #5 Anchoring Rebar for Series #15, #18 and #24) Rebar thru ALL of the Anchor Stands and hammer the Rebar STRAIGHT into the sub-base 12” or more, depending on soil or sub-base conditions, to hold the forms in place and prevent flotation when placing concrete. At this step, the Rebar tip should be left about 1-1/2” to 2” above the top of the Anchor Stand. Snug the Hex Bolt enough to hold the assembly on the Rebar but do not tighten at this time.

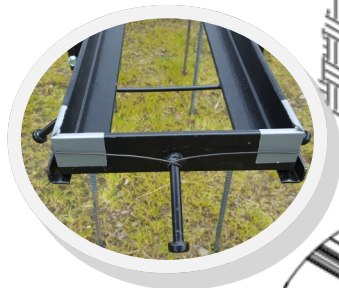

HEPFUL HINT:
Duct tape or equal may be used to temporarily secure the End Frame while wire tying in place.

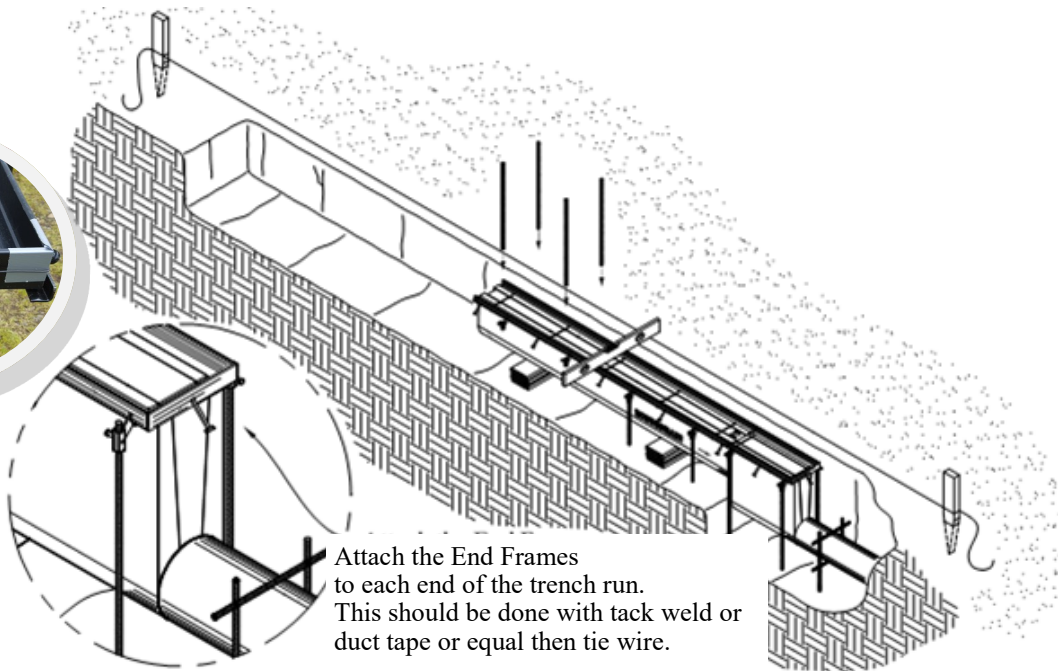

Attach the End Frames to each end of the trench run. This should be done with tack weld or duct tape or equal then tie wire.

Pipe

Make sure the Outlets fit snugly against the EPS Form at the trench outlet. Cover the pipe end with duct tape to prevent concrete infiltration and secure the pipe to prevent movement during concreting.

Step 9: Finish Setting the Remainder of the EconoDrain System

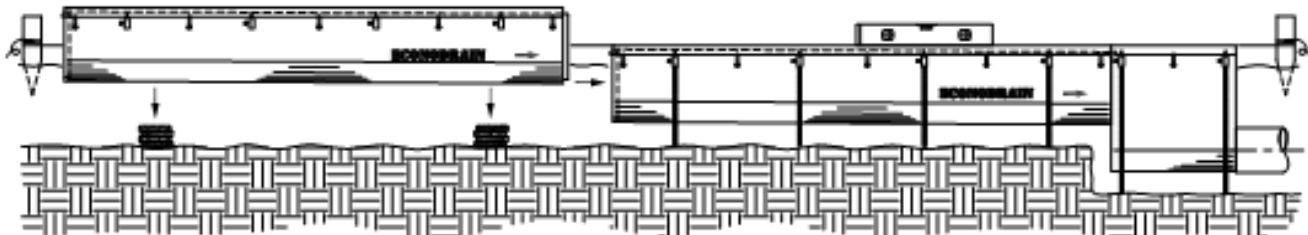

Step 10: Installation of EconoDrain EPS Trench Forming Assembly

Loosen the Hex Bolt and set the EconoDrain assemblies slightly higher than the finished elevation by sliding the unit upward until the tip of the rebar is 1/8" to 1/4" above the top of the Anchor Stand. Tighten the Hex Bolts securely.

Remove the wood blocks from beneath the EPS Form.

When all the units are set in this manner, tap the top of the rebar with a hammer to lower the unit assembly to the precise elevation. Use a level and string-line to assure correct alignment lengthwise as well as side to side.

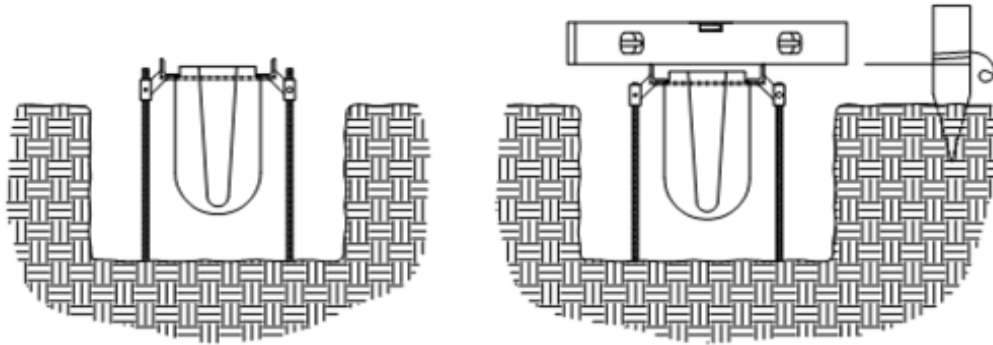

Step 11: Final Adjustments - Wire Tie the Sections Together

Tie Wire sections together, loosely, using the anchor studs at each end of the frame assembly as shown.

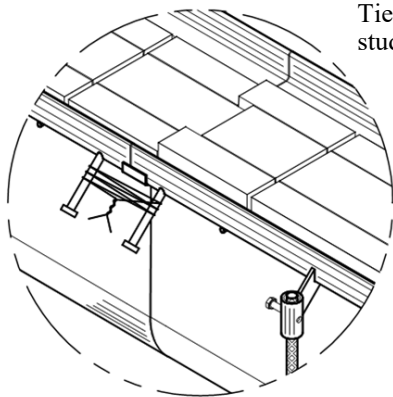

Step 12: Duct Tape the EPS Form Joints

Apply duct tape to form joints. Apply tape smoothly avoiding wrinkles and press to assure adhesion to EPS Form.

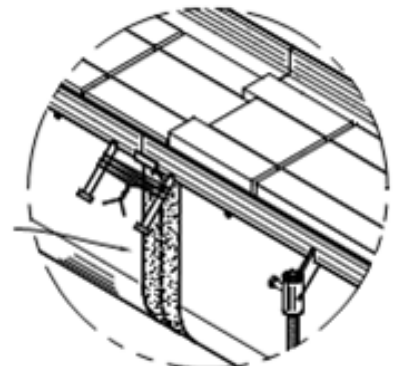

Step 13: Finish Applying Form Release at EPS Form Joints

A brush or sprayer may be used to apply form release around the joint areas left uncoated in Step 1.

AS ALWAYS, THE FORM RELEASE MUST BE DRY PRIOR TO POURING CONCRETE!

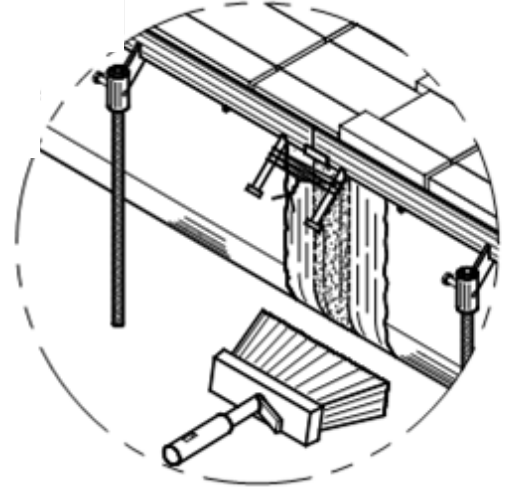

Step 14: Installing EconoDrain Form in the Deeper Portion of the System

Holes are provided through the center of the deeper EPS Forms for insertion of rebar. These holes maintain vertical alignment during initial concrete placement.

The rebar is driven only a few inches into the ground or sub-base.

Concrete must be filled on both sides of the form as evenly as possible. Multiple passes on either side are preferable while avoiding filling the trench from one side.

See Step 15: How to Pour Concrete Around EconoDrain Trench Forming System.

The rebar **MUST** be removed once the concrete/form pressure equalizes but prior to the concrete setting up.

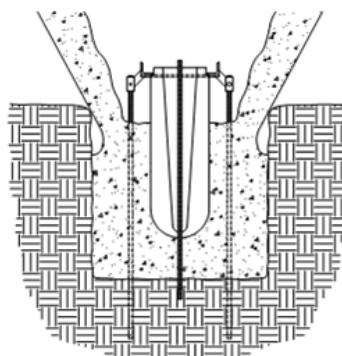

Step 15: Pour Concrete Around EconoDrain Trench Forming System

Alternate pouring and consolidation on either side of the EconoDrain System Form until the desired elevation is reached as shown. Avoid concrete lift cold joints.

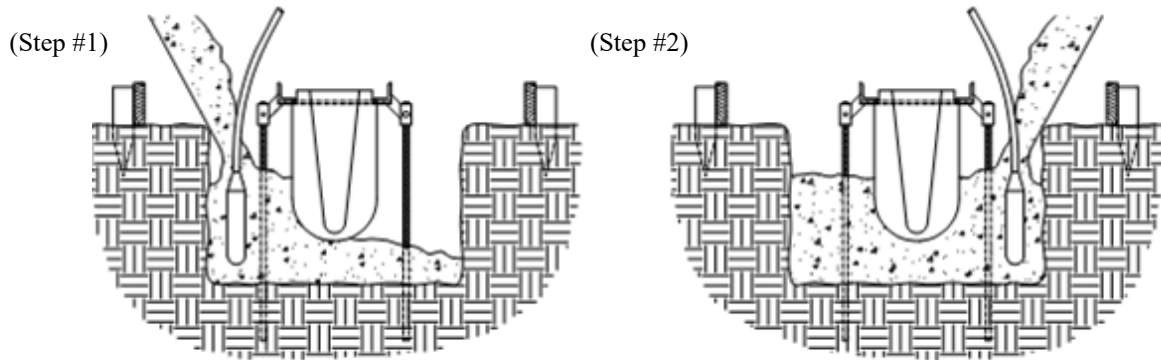

A diagram for a Concrete Pour Shield is shown on page 17. You may wish to consider building and using this to help eliminate un-necessary clean-up at the end of the job.

EPS Foam - Grate Frame Inserts: All shipments include 1-1/2" x 1-1/2" x 48" long EPS foam, grate frame inserts to be taped in the steel grate frame rail to keep the rail clean from concrete during the pour.

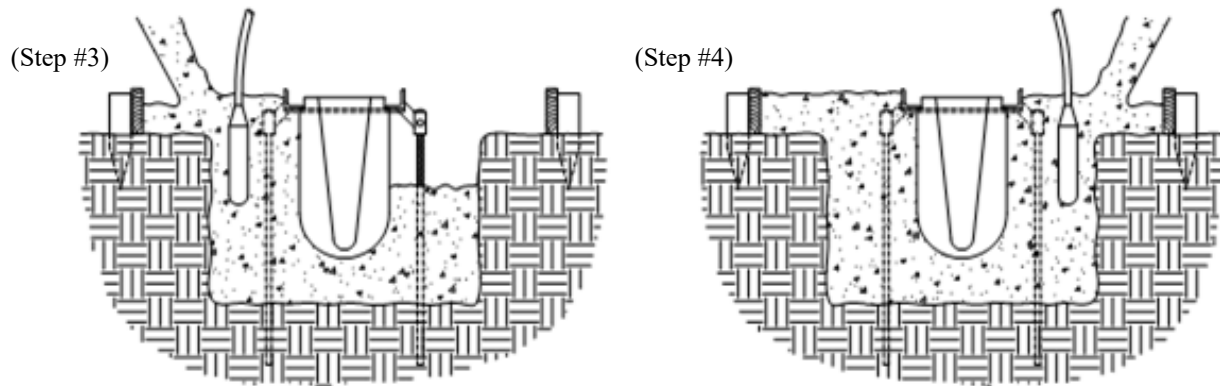

Finish Concrete

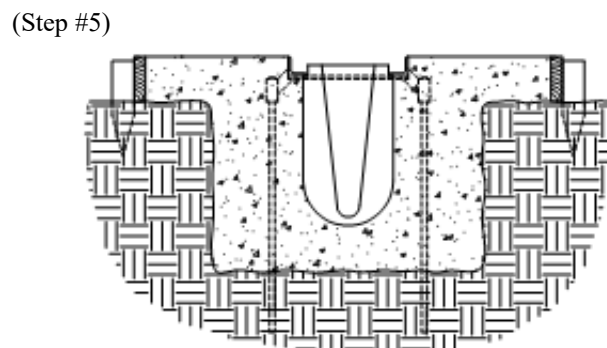

Step 16: EPS Form Removal

Cut and remove spacer rods using a hand grinder or power saw equipped with a steel cutting abrasive blade.

Cut the spacer rod adjacent to the frame angling the grinder / saw to avoid dulling the blade on the concrete wall

For the Bolt-In-Place Spacer Bar Rail System, use a 1/2" socket to remove bolts.

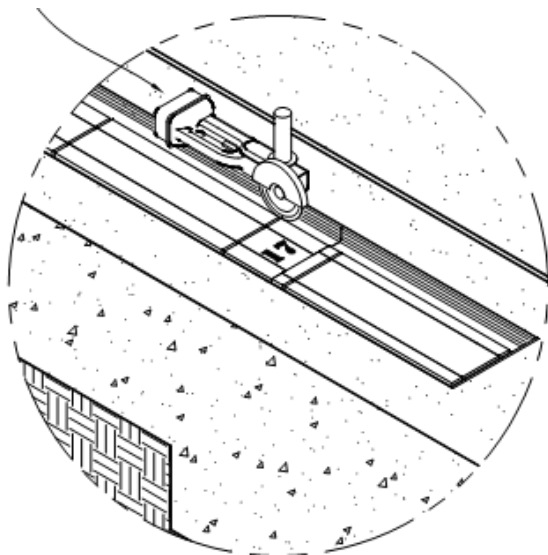
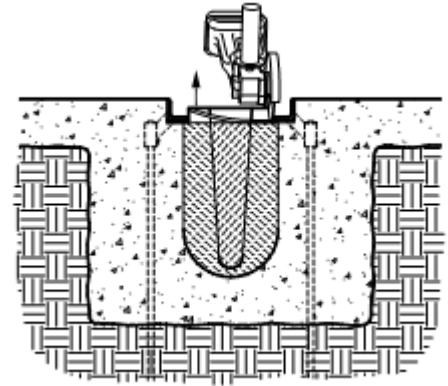

1. Remove the EPS Form Center Wedge.
2. Collapse the side walls.
3. Remove the EPS Form Outer Sections from the trench.

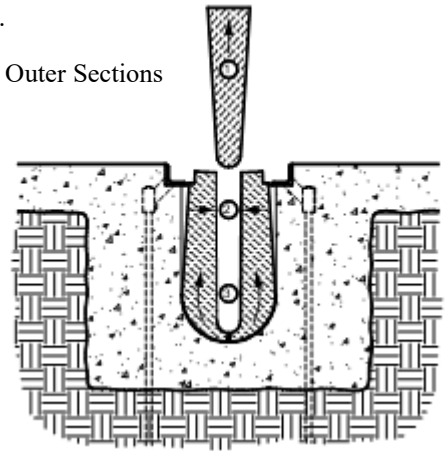

CAUTION: Do not use Gasoline to dissolve EPS. This violates EPA pollution policies and creates hazardous conditions due to fire and explosion potential.

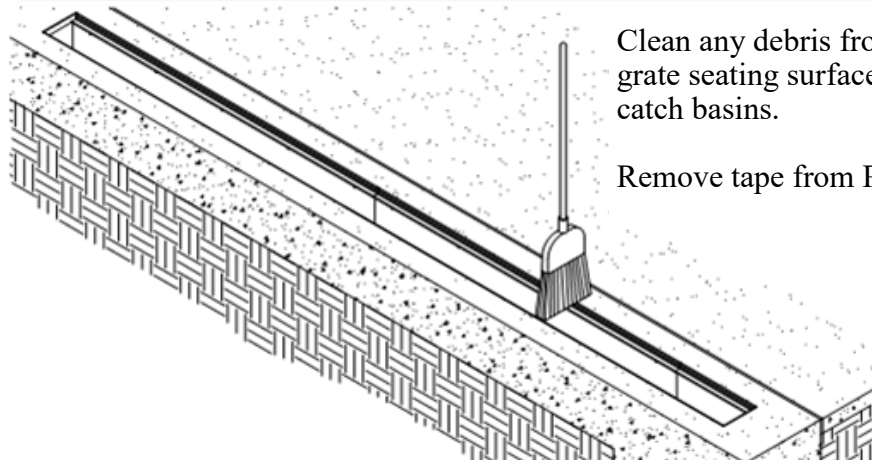

Clean any debris from the frame grate seating surface, trench and catch basins.

Remove tape from PVC pipe ends.

Step 17: Cleanup

Step 18: Grating Installation

After cleaning the area, you are ready to place the grates in the trench. We recommend using Grate Locking Devices to secure them to the rails.

ALLOW 1/8" GAP BETWEEN GRATES WHEN PLACING THEM IN THE FINISHED TRENCH.

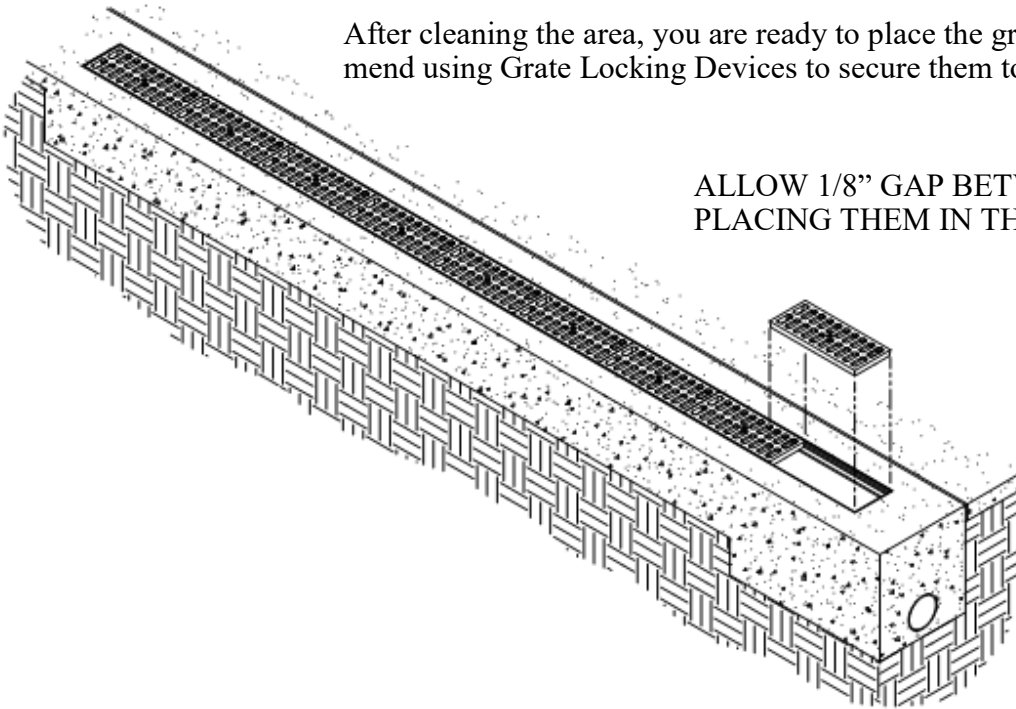

Step 19: Grate Locking Device Installation

Bolt, Washer and Toggle.

Proper orientation of the Lock Toggle:
THE BEND FACED DOWNWARDS

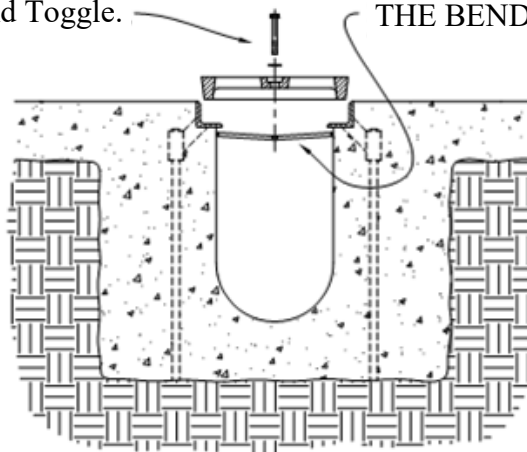

Special Installation: Intersection Kits

Intersection Kits are used for forming left and right L's, T's and four-way trench intersections for EconoDrain Series #4, #6, #8, #10, #12, #15, #18, #24 and PT-2 Systems.

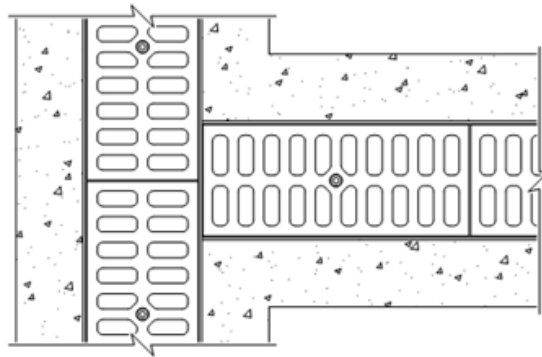

FINISHED PLAN VIEW

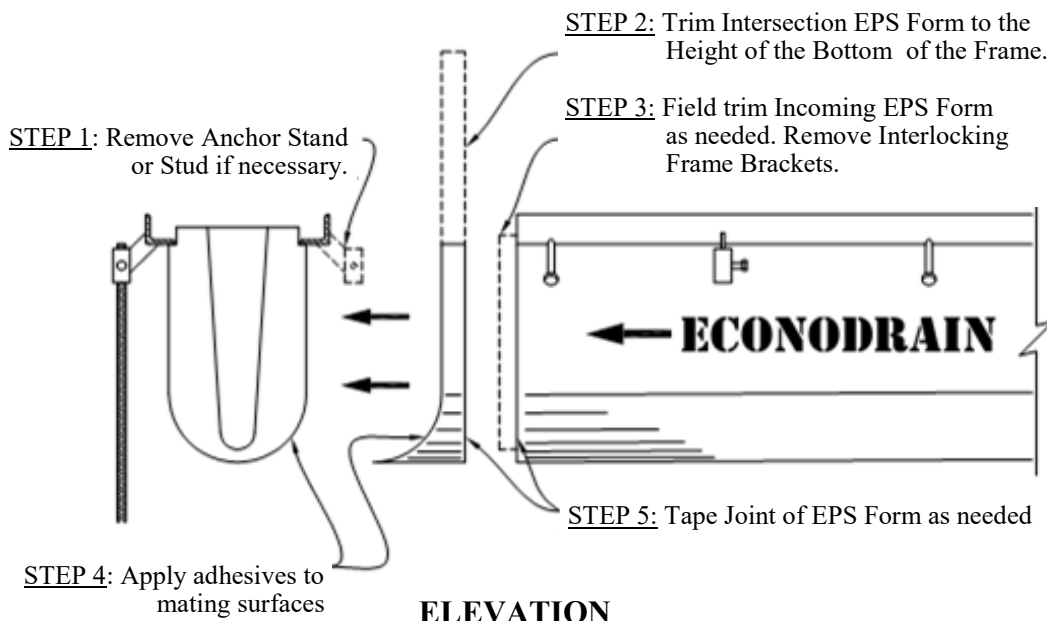

Special Installation: Installing EconoDrain in Poor Sub-Grade Conditions

To further assure the EPS forms will not float in loose or very poor sub-surface conditions, concrete should be placed as follows:

Complete Steps 1 through 14 in the EconoDrain Installation Instructions. Then proceed as follows:

Wire 2x4's across the top of the metal Frame Rail, as shown here, to prevent the assembly from floating and side shifting. The 2x4 should be firmly anchored prior to concreting. Rebar, metal, or wooden stakes are used to secure the free end of the 2x4 into compacted sub-base or sub-grade. Threaded concrete anchor bolts, such as Tapcon[™] brand or similar, can be used to secure the free end of the 2x4 into adjacent concrete slab. A minimum of two (2) additional 2x4 reinforcement cross bars should be used per 8' EconoDrain Form Section in conjunction with previously driven rebar.

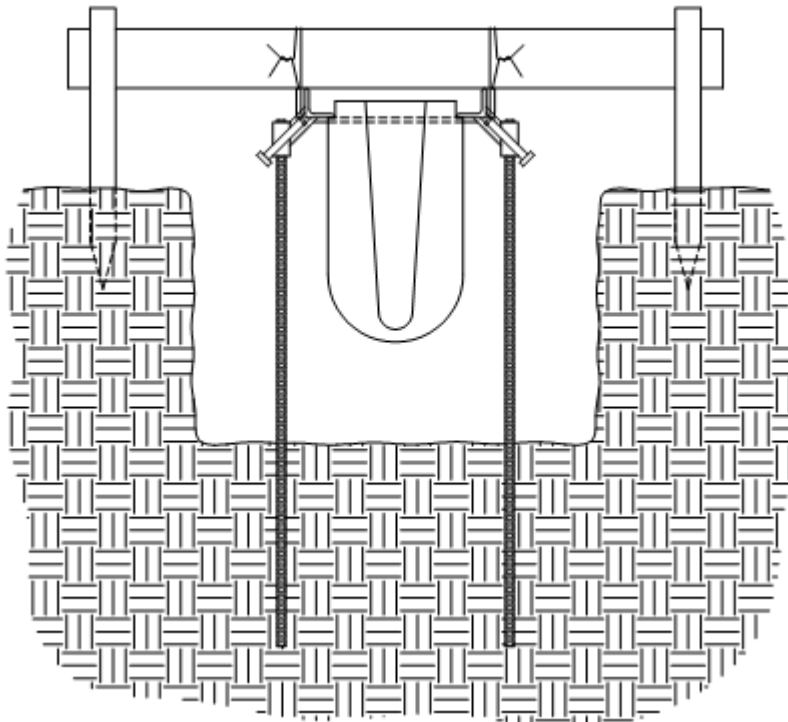

Helpful Hint: Concrete Pour Shield

The time required to construct this useful device will pay dividends in shorting clean-up time at the end of the project.

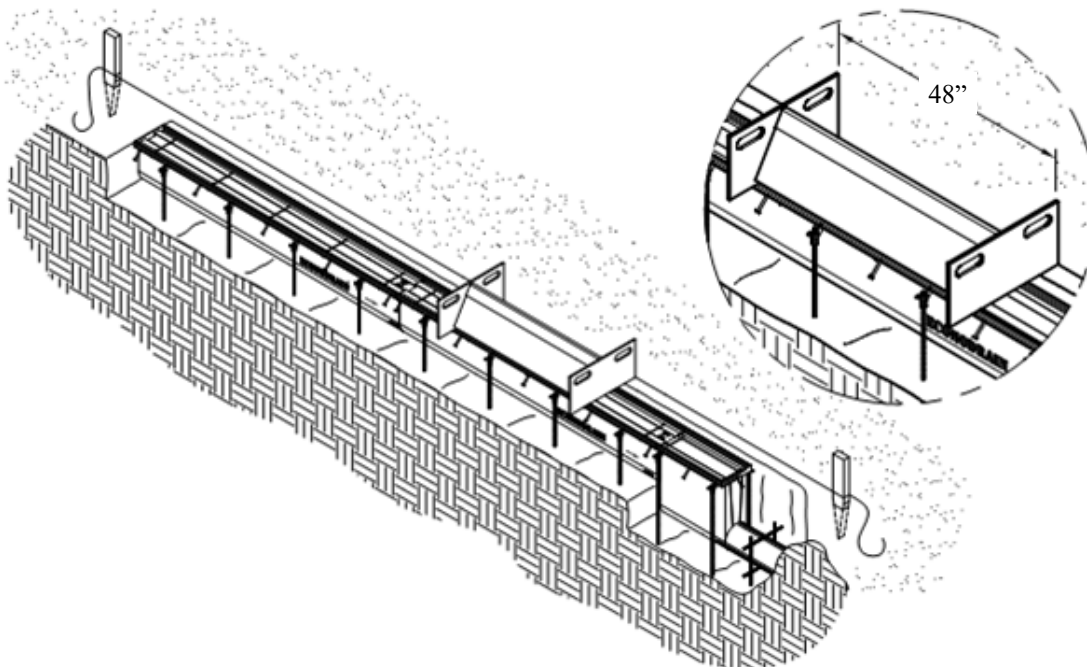
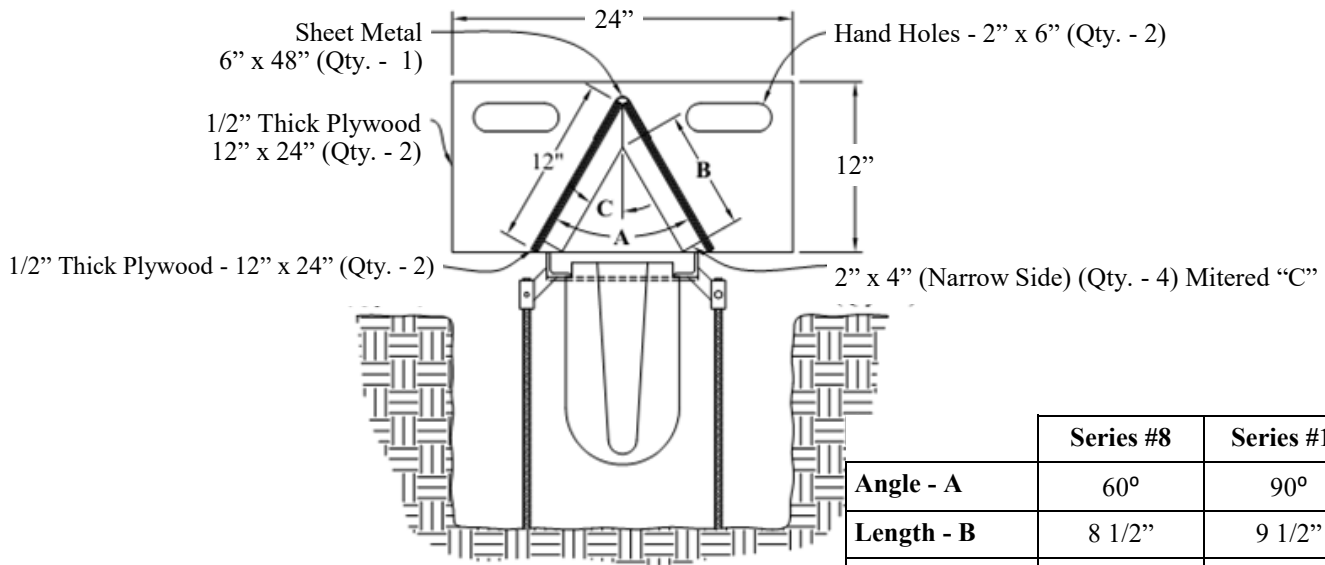

Installation of PT-2 Two-Point Lockdown Grate Trench Forming System

The EconoDrain PT-2 System is available in #8 and #12 Systems.

Lockdown Methods: Two Point Lockdown or Center Locking Device with Bolt, Washer and Toggle

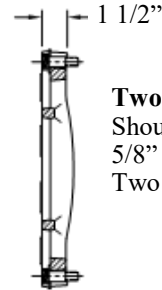
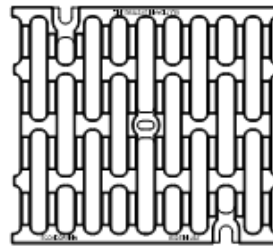
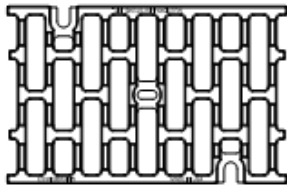

Two Point Lockdown:
Shoulder Bolt -
5/8" x 1-1/2" x 1/2-13 UNC
Two (2) Bolts per Grate

PT-2, #8 Heavy Duty Grate:

Part #: EG-1016-2DI-A
Size: Nominal 10" wide x 16" long
Open Area: 54 percent
Material: Ductile Iron
Finish: Uncoated - Standard
Hot Dip Galvanized - Optional
FAA AC 150 5320-6D Load Conditions
AASHTO M306: H20 and HS25

PT-2, #12 Heavy Duty Grate:

Part #: EG-1416-2DI-A
Size: Nominal 14" wide x 16" long
Open Area: 49 percent
Material: Ductile Iron
Finish: Uncoated - Standard
Hot Dip Galvanized - Optional
FAA AC 150 5320-6D Load Conditions
AASHTO M306: H20 and HS25

CAUTION: When installing grates, remove temporary Hex Bolt and discard, then attach grate with the permanent Shoulder Bolt and Washer provided by MultiDrain Systems.

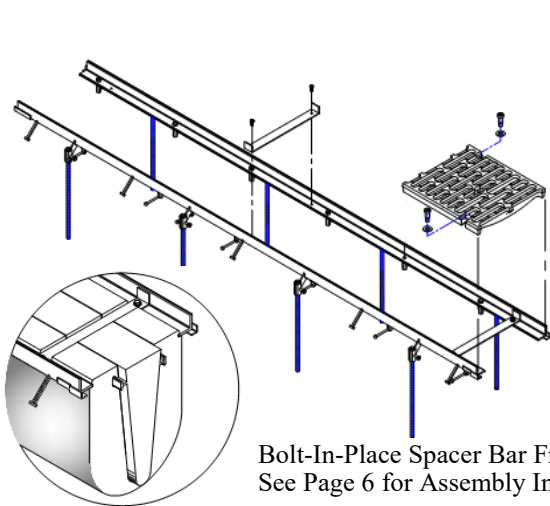

Bolt-In-Place Spacer Bar Frame Assembly
See Page 6 for Assembly Instructions

After the system is installed and concrete cured, remove temporary spacer bar, the EPS foam form and temporary Hex Bolt, then attach the grate with the permanent Shoulder Bolt and Washer.

Follow Steps 1 thru 17 as shown in the Installation Instructions

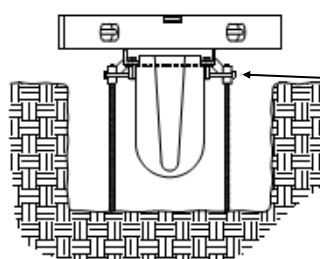
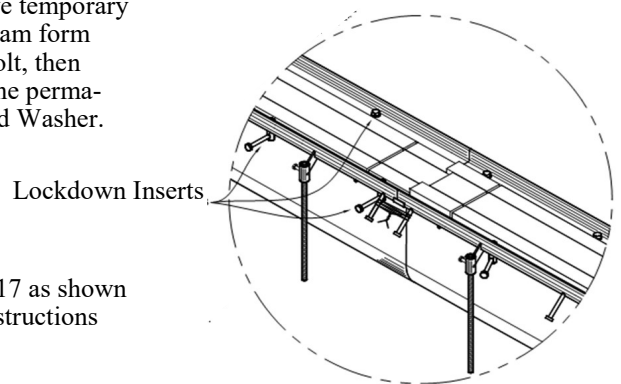

The Frame Assembly is shipped to the jobsite with the Lockdown Inserts bolted to the Frame Rails.

Make sure the Anchor Studs on the Lockdown Inserts point **OUTWARD** prior to installing.

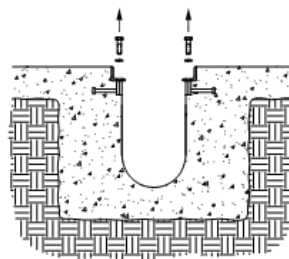

Prior to grating installation, remove the temporary Hex Bolts securing the Lockdown Inserts. The holes should be free of any debris or concrete prior to installing the PT-2 Gratings.

INSTALL the PT-2 Gratings and secure them, 5/8" x 1" Socket Shoulder Bolt and Washer.

Guidelines: Excavate your trench depth equal to the Overall Average Depth (Shown below) plus an additional 6 inches.

Final Concrete thickness per local engineering regulations and project specifications. CHECK BEFORE YOU DIG!

Part Number	EconoDrain #4	EconoDrain #6	EconoDrain #8	EconoDrain #10	EconoDrain #12	EconoDrain #15	EconoDrain #18	EconoDrain #24
04	4.5	n/a	n/a	n/a	n/a	n/a	n/a	n/a
05	5.0	n/a	n/a	n/a	n/a	n/a	n/a	n/a
06	5.5	6.25	6.25	n/a	n/a	n/a	n/a	n/a
07	6.0	6.75	6.75	n/a	n/a	n/a	n/a	n/a
08	6.5	7.25	7.25	n/a	n/a	n/a	n/a	n/a
09	7.0	7.75	7.75	n/a	n/a	n/a	n/a	n/a
10	7.5	8.25	8.25	8.25	8.25	n/a	n/a	n/a
11	8.0	8.75	8.75	8.75	8.75	n/a	n/a	n/a
12	8.5	9.25	9.25	9.25	9.25	n/a	n/a	n/a
13	9.0	9.75	9.75	9.75	9.75	n/a	n/a	n/a
14	9.5	10.25	10.25	10.25	10.25	n/a	n/a	n/a
15	10.0	10.75	10.75	10.75	10.75	n/a	n/a	n/a
16	10.5	11.25	11.25	11.25	11.25	n/a	n/a	n/a
17	11.0	11.75	11.75	11.75	11.75	n/a	n/a	n/a
18	11.5	12.25	12.25	12.25	12.25	12.25	12.25	n/a
19	12.0	12.75	12.75	12.75	12.75	12.75	12.75	n/a
20	12.5	13.25	13.25	13.25	13.25	13.25	13.25	n/a
21	13.0	13.75	13.75	13.75	13.75	13.75	13.75	n/a
22	13.5	14.25	14.25	14.25	14.25	14.25	14.25	n/a
23	14.0	14.75	14.75	14.75	14.75	14.75	14.75	n/a
24	14.5	15.25	15.25	15.25	15.25	15.25	15.25	15.25
25	15.0	15.75	15.75	15.75	15.75	15.75	15.75	15.75
26	15.5	16.25	16.25	16.25	16.25	16.25	16.25	16.25
27	16.0	16.75	16.75	16.75	16.75	16.75	16.75	16.75
28	16.5	17.25	17.25	17.25	17.25	17.25	17.25	17.25
29	17.0	17.75	17.75	17.75	17.75	17.75	17.75	17.75
30	17.5	18.25	18.25	18.25	18.25	18.25	18.25	18.25
31	18.0	18.75	18.75	18.75	18.75	18.75	18.75	18.75
32	18.5	19.25	19.25	19.25	19.25	19.25	19.25	19.25
33	19.0	19.75	19.75	19.75	19.75	19.75	19.75	19.75
34	19.5	20.25	20.25	20.25	20.25	20.25	20.25	20.25
35	20.0	20.75	20.75	20.75	20.75	20.75	20.75	20.75
36	20.5	21.25	21.25	21.25	21.25	21.25	21.25	21.25
37	21.0	21.75	21.75	21.75	21.75	21.75	21.75	21.75
38	21.5	22.25	22.25	22.25	22.25	22.25	22.25	22.25
39	22.0	22.75	22.75	22.75	22.75	22.75	22.75	22.75
40	22.5	23.25	23.25	23.25	23.25	23.25	23.25	23.25
41	23.0	23.75	23.75	23.75	23.75	23.75	23.75	23.75
42	23.5	24.25	24.25	24.25	24.25	24.25	24.25	24.25
43	24.0	24.75	24.75	24.75	24.75	24.75	24.75	24.75
44	24.5	25.25	25.25	25.25	25.25	25.25	25.25	25.25
45	25.0	25.75	25.75	25.75	25.75	25.75	25.75	25.75

*The above are Overall Average Depths in Inches. Custom Depths are available, consult with your MultiDrain Specialist for details.



We Help You Plan for Rainy Days

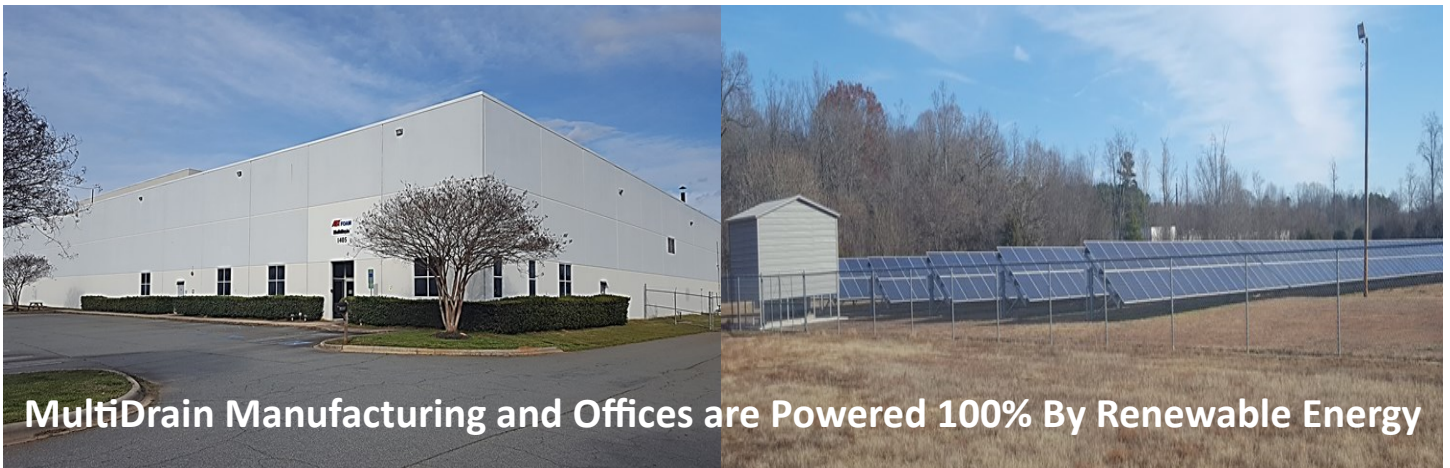

MultiDrain®
We Drain Your Site, Not Your Budget!

MultiDrain Systems, Inc.
1405 Industrial Dr. • Statesville, NC 28625
P: (704) 508-1010 • (800) 433-1119 • F: (704) 508-1011
www.multidrainsystems.com

EconoDrain®
www.multidrainsystems.com

"DISCLAIMER: The customer and the customer's architects, engineers, consultants and other professionals are completely responsible for the selection, installation, and maintenance of any product purchased from MULTIDRAIN SYSTEMS, INC., and EXCEPT AS EXPRESSLY PROVIDED IN MULTIDRAIN'S STANDARD WARRANTIES, MULTIDRAIN MAKES NO WARRANTY, EXPRESS OR IMPLIED, AS TO THE SUITABILITY, DESIGN, MERCHANTABILITY, OR FITNESS OF THE PRODUCT FOR CUSTOMER'S APPLICATION. Copies of MultiDrain's standard warranties are available upon request."

MultiDrain Systems, Inc. Trade Mark Products: Alfa Channel®, Alfa Slot®, EconoDrain® and MultiDrain. These products are protected by one or more U.S. patents.

Copyright © 2020