

Adjustable Joist Hanger

Temporary support bracket for lumber joists and bridge deck material

Adjustable Joist Hangers are available in two sizes for 2x and 4x lumber joists. Both sizes adapt to concrete girders and steel beams, while supporting the bridge deck formwork.

Adjustable Joist Hangers are installed by placing the support angle on top of the beam flange and inserting the lumber joist into the hanger bracket. Turning the adjusting handle will then raise/lower the bridge deck formwork to the proper elevation.

Properly spacing the Adjustable Joist Hangers eliminates the need for walers or other additional deck support. This simplifies the formwork, minimizes lumber requirements and reduces the related labor cost.

Concrete placement should always be at mid-span and evenly distributed outward towards the hangers to prevent eccentric loading. Stripping the bridge deck formwork starts by removing the release pin, allowing the adjusting handle and joist to slide out from below.

With no joists in the way, the Adjustable Joist Hangers are removed from the beam flange along with the temporary decking material. Since the hangers are reusable, they can be stored for the next project.

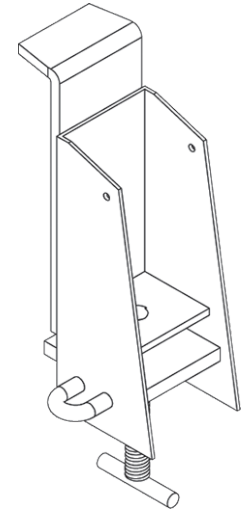

Adjustable Joist Hanger for 2x lumber

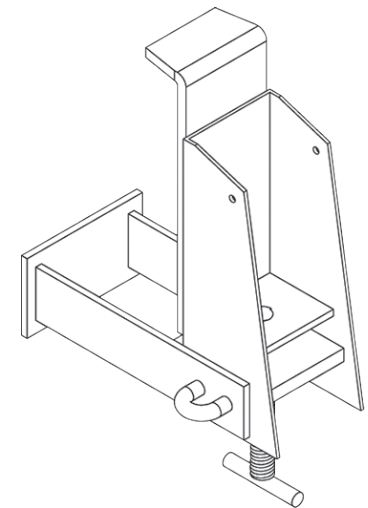

Adjustable Joist Hanger for 2x lumber with beam offset

Adjustable Joist Hangers		
Part No.	Description	SWL*
SBAJH2X	Adjustable Joist Hanger 2x	3,000 lbs
SBAJH2XWO	Adjustable Joist Hanger 2x wOffset	3,000 lbs
SBAJH4X	Adjustable Joist Hanger 4x	3,000 lbs
SBAJH4XWO	Adjustable Joist Hanger 4x wOffset	3,000 lbs

* Safe Working Load (SWL) is based on a 2:1 safety factor.

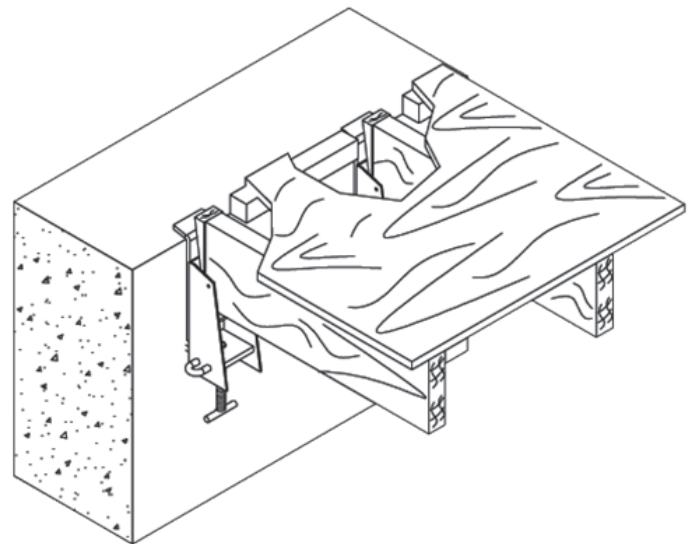
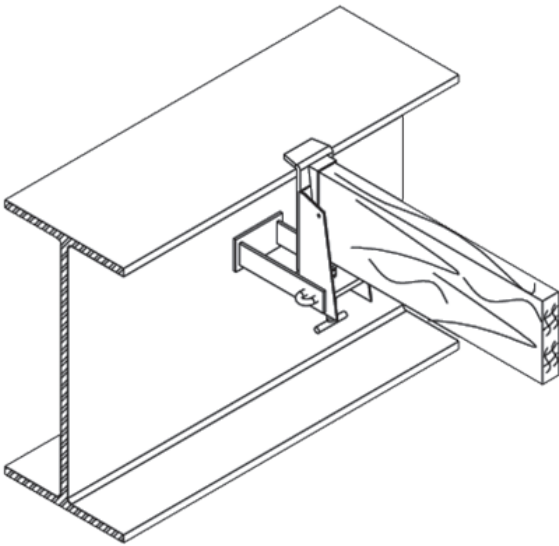
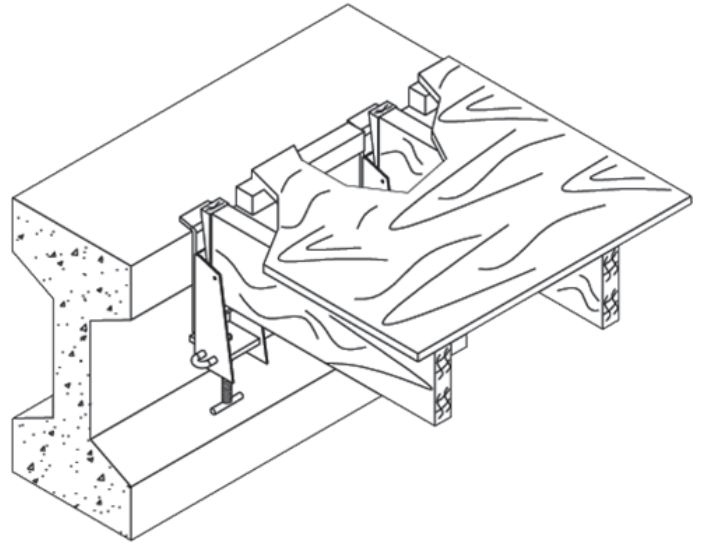
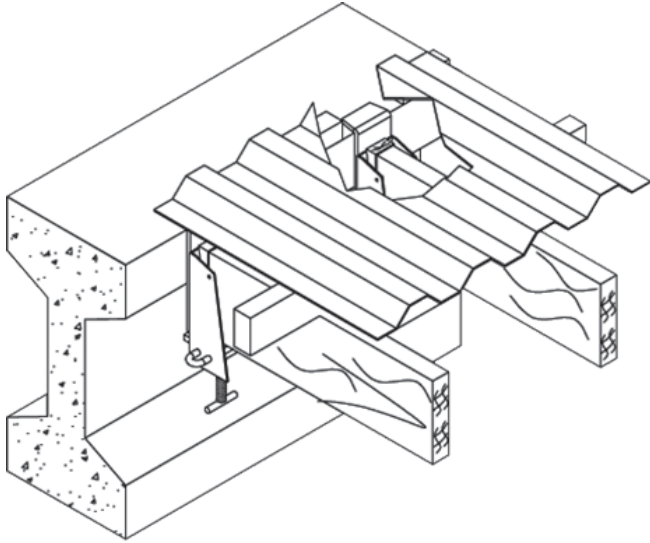

This chart is used to determine the allowable spacing for the Adjustable Joist Hanger when the maximum clear span and concrete thickness is known. Design load is based on 160 pounds per cubic foot for concrete and 50 pounds per square foot live for load. This chart is based on the use of Southern Pine, Grade #2 (or equivalent strength) lumber joists.

Concrete Thickness	Design Load	Joist Lumber	Clear Span					
			5'-0"	6'-0"	7'-0"	8'-0"	9'-0"	10'-0"
			Joist Spacings Based on 3/4" Plywood					
5"	116.7 psf	2 x 6	23"	21"	13"	8"	5"	3"
		2 x 8	23"	23"	23"	18"	12"	8"
		2 x 10	23"	23"	23"	23"	21"	16"
		2 x 12	23"	23"	23"	23"	23"	23"
6"	130.0 psf	2 x 6	22"	18"	12"	7"	5"	3"
		2 x 8	22"	22"	22"	17"	10"	7"
		2 x 10	22"	22"	22"	22"	19"	19"
		2 x 12	22"	22"	23"	22"	22"	21"
8"	156.7 psf	2 x 6	21"	15"	10"	6"	4"	2"
		2 x 8	21"	21"	18"	14"	9"	6"
		2 x 10	21"	21"	21"	21"	16"	12"
		2 x 12	21"	21"	21"	21"	21"	18"
10"	183.3 psf	2 x 6	19"	13"	8"	5"	3"	100"
		2 x 8	20"	20"	15"	12"	7"	95"
		2 x 10	20"	20"	20"	17"	13"	10"
		2 x 12	20"	20"	20"	20"	21"	18"
12"	210.0 psf	2 x 6	17"	11"	7"	5"	3"	2"
		2 x 8	19"	18"	13"	10"	6"	4"
		2 x 10	19"	19"	19"	15"	12"	9"
		2 x 12	19"	19"	19"	21"	16"	13
5"	116.7 psf	4 x 6	23"	23"	23"	19"	12"	8"
		4 x 8	23"	23"	23"	23"	23"	18"
		4 x 10	23"	23"	23"	23"	23"	23"
		4 x 12	23"	23"	23"	23"	23"	23"
6"	130.0 psf	4 x 6	22"	22"	22"	17"	11"	7"
		4 x 8	22"	22"	22"	22"	22"	16"
		4 x 10	22"	22"	22"	22"	22"	22"
		4 x 12	22"	22"	22"	22"	22"	22"
8"	156.7 psf	4 x 6	21"	21"	21"	14"	9"	6"
		4 x 8	21"	21"	21"	21"	20"	13"
		4 x 10	21"	21"	21"	21"	21"	21"
		4 x 12	21"	21"	21"	21"	21"	21"
10"	183.3 psf	4 x 6	20"	20"	19"	12"	8"	5"
		4 x 8	20"	20"	20"	20"	17"	11"
		4 x 10	20"	20"	20"	20"	20"	20"
		4 x 12	20"	20"	20"	20"	20"	20"
12"	210.0 psf	4 x 6	19"	19"	17"	11"	7"	4"
		4 x 8	19"	19"	19"	19"	15"	10"
		4 x 10	19"	19"	19"	19"	19"	19"
		4 x 12	19"	19"	19"	19"	19"	19"