

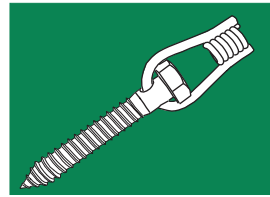

Coil-Lag™

One-Sided Forming Hardware



SCL-4 Coil-Lag™

MADE IN USA

The Steel Dog® **Coil-Lag™** is designed to provide a temporary means of attaching formwork to wood structures. Typical application: one-sided forming against soldier piles with wood lagging.

FEATURES:

- Standard hex head lag bolt for socket wrench installation.
- Swivel loop coil tie end to accommodate misalignment between lag bolt placement and formwork tie location.
- Accepts standard 1/2" coil rod or 1/2"-13 NC rod (SCL-4NC)
- Less expensive than toggle ties, and doesn't require clear space behind timber (compacted soil not a problem).
- Eliminates expensive external bracing or welding.
- Long version (SCL-4-10) can be used with foam for waterproofing installations

MATERIAL: Bolt is ASTM A307. Swivel loop wire is AISI C1038.

FINISH: None. Zinc coatings available: consult factory.

MAXIMUM SAFE WORKING LOAD: 3000 Lbs. (2-to-1 safety factor). *Actual Safe Working Load will depend on pull-out strength of lag in wood and off-axis loading angle.* See tables at right.

INSTALLATION:

- Install only into pre-drilled hole (9/16" diameter MAX)
- Use wax or other suitable solid lubricant on lag bolt threads (especially in hardwood species.)
- Screw bolt into wood using wrench on bolt hex head only. *Do not use swivel loop to turn bolt.* If excessive resistance is met, unscrew bolt and re-lubricate or change bolt location. If using powered socket driver (such as right angle drill or impact wrench), apply 400 ft-lb max torque. Bolt should be screwed into wood until swivel loop is just in contact with wood surface (SCL-4) or until threaded through full thickness of timber (SCL-4-10).
- If wood splits when installing lag bolt, the bolt will not hold the rated load. Move bolt location at least 1-1/2" across grain.
- Swivel loop may be loaded up to 30° off-axis when rotated in "A" direction, and up to 90° off-axis when rotated in the "B" direction (see diagram at right).
- Generally, *the withdrawal resistance of the bolt from the wood and the off-axis load angle will determine the allowable tie load* on the swivel loop coil. When loading off-axis, (see tables at right), consideration must be given to translation forces or torque on timber element due to lateral bolt loads.
- Not intended for installation into end grain.

WOOD LAGGING LOADS

- Because wood lagging timber widths vary, and are unlikely to match the formwork tie spacing, the lag bolt locations will vary on the pattern of wood lagging. Ideally, there should be a row of **Coil-Lags™** attached to every lagging timber so that the liquid concrete pressure is spread evenly. If some timbers are skipped, then timbers without **Coil-Lags™** will see a net bending moment in a direction opposite to the soil pressure loading, and adjacent timbers with **Coil-Lags™** will see a net bending moment in the same direction as the soil pressure load. **THIS ADDITIONAL LOAD ON THE TIMBERS MUST BE FACTORED INTO THE DESIGN OF THE SOLDIER PILING, FORMWORK, AND ALLOWABLE POUR PRESSURE.**

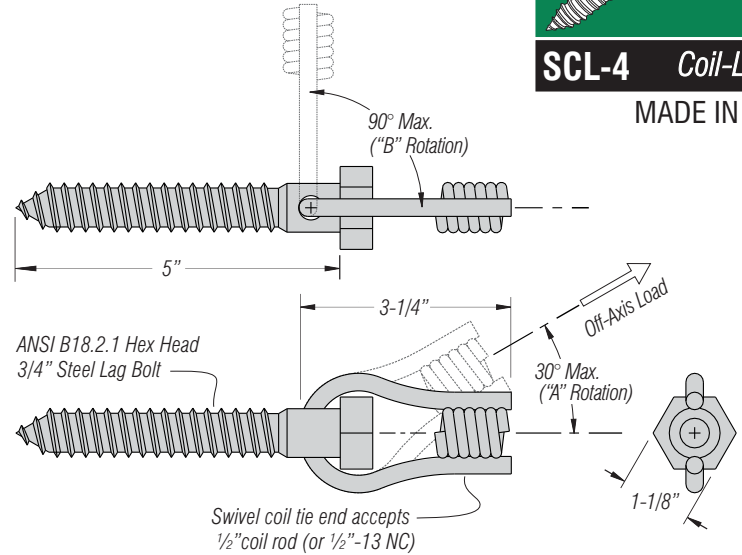

	<p>SCL-4/SCL-4-10: Accept 1/2" coil rod only. SCL-4NC: Coil tapped to accept both 1/2" coil rod AND 1/2"-13NC machine threads</p> <p><i>*For Coil-Lag itself at 2-to-1 Safety Factor. ACTUAL ALLOWABLE LOAD WILL DEPEND ON INSTALLATION AND TYPE OF WOOD. SEE TABLES BELOW.</i></p>		
	Product Code	SCL-4	SCL-4NC
Safe Working Load*	3000 lbs		
Lag Screw Size	3/4"		
Lag Screw Length	5"		10"
Accepts Threaded Rod: 1/2" coil rod	Yes	Yes	Yes
1/2"-13 NC	No	Yes	No
Box Quantity	50		25
Box Weight	37 lbs		34 lbs

Wood Species	Specific Gravity ³	Axial Lag Withdrawal Load In Different Thickness Wood ^{1,2}						Off-Axis Load Angle	Off-Axis Load Factor ^{4,5,6}	
		1-1/2"	2"	2-1/2"	3"	3-1/2"	4"		With Grain	Across Grain
Oak, Red	0.62	1590	2120	2660	3190	3720	4250	10°	1.0	1.0
Western Larch	0.53	1260	1680	2100	2520	2940	3360	30°	1.0	0.7
Douglas Fir	0.50	1150	1540	1920	2310	2690	3080	45°	0.9	0.5
Western Hemlock	0.48	1090	1450	1810	2170	2530	2890	60°	0.7	0.4
South. Yellow Pine	0.48	1090	1450	1810	2170	2530	2890	90°	0.5	0.3
Eastern White Pine	0.37	730	980	1220	1470	1710	1960			

1. Load in lbs at approximate 3-to-1 safety factor. Figures based on $p=8, 100G^{3/2}D^{3/4}L$, where G is specific gravity, D is lag shank diameter, and L is penetration of threaded portion in wood (from Forest Products Laboratory Wood Handbook, 1999). **Load not to exceed 3000 lbs** in any case (shaded areas represent pull-out values which exceed max. SWL of the Coil-Lag™).
2. All load ratings are for bolt installation into side grain in sound wood, minimum 1 1/2" from edge and 4" from end of timber.
3. Specific gravity (density) figures are typical for kiln-dried samples of the listed species. **Load ratings based on S.G. figures shown; actual S.G. values for wood vary widely.** Unless actual S.G. is known, use next lower figure for load calculations, or perform pull tests on samples of wood to be used.
4. **SCL-4/SCL-4NC ONLY.** SCL-4-10 **NOT** rated for off-axis loading.
5. Multiply off-axis load factor times axial lag withdrawal load for allowable off-axis load. Example: 60° off-axis, with-the-grain load into 3" Douglas Fir would be $0.7 \times 2310 = 1617$ lbs max. Remember: this is the load applied to the swivel loop coil, **NOT** the axial load on the lag.
6. Off-axis load ratings apply only to bolts that are threaded into timber until swivel loop is in contact with wood surface.

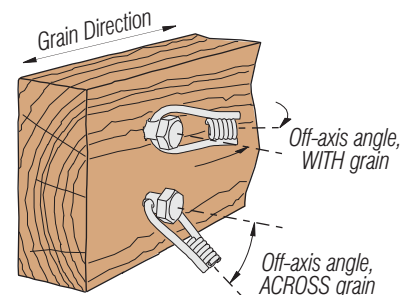

One-Sided Wall Application Against Wood Lagging

Using Transition Ties™ and Coil-Lags™

This example shows how Steel Dog® **Coil-Lags™** are used to secure Steel-Ply® forms to wood lagging for a one-sided pour. (The same concept applies to 1-1/8" forms, aluminum forms, or the other forming systems that Transition Ties™ connect to.)

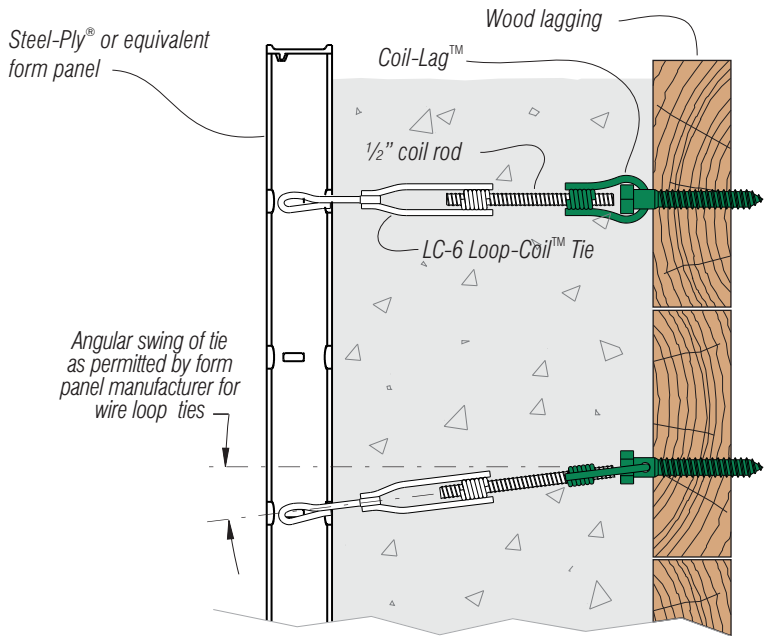

Installation

Drill 9/16" (MAX) hole.
(Min. 7/16" in softwood)

Stay min. 1-1/2" from edge of board

Avoid knots, splits, or areas of unsound wood

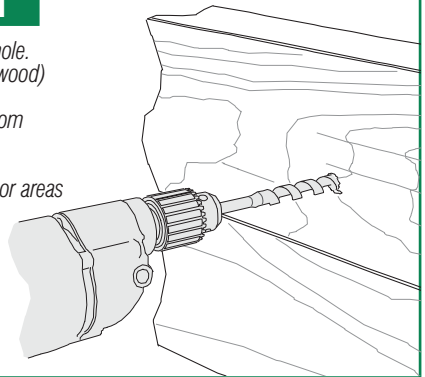

Lubricate lag bolt threads with wax, soap, or other suitable solid lubricant

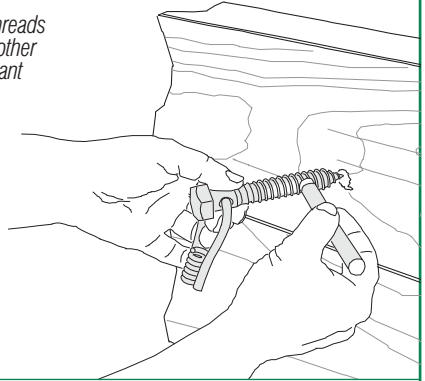

Screw into wood using impact wrench or socket driver on bolt hex head (400 ft-lb torque MAX).

If excessive resistance is met, unscrew bolt and re-lubricate

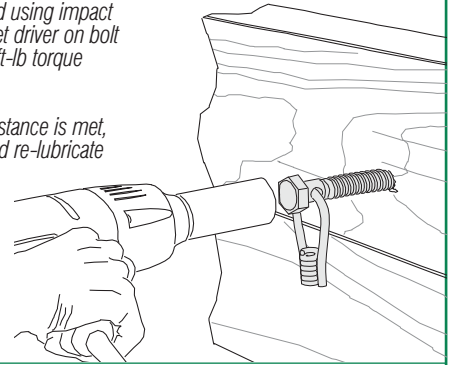

Thread desired length of 1/2" coil rod or 1/2"-13 rod into swivel loop coil

MAKE SURE THAT THREADED ROD EXTENDS AT LEAST 1/2" PAST COIL

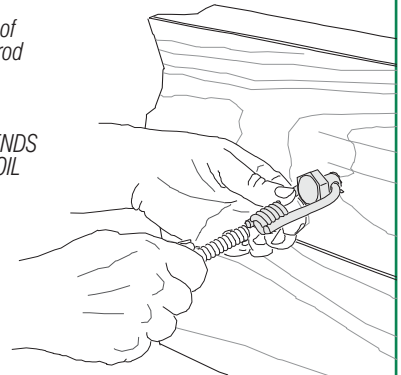

Off-the-Shelf Solutions for Many Forming Problems

Choose Your Forming System

The Steel Dog® **Coil-Lag™** is part of a versatile family of off-the-shelf, interchangeable forming components using industry-standard 1/2" coil rod as the threaded element. Choose the components for your form system and application and get an adjustable, labor-saving, no lead-time forming solution.

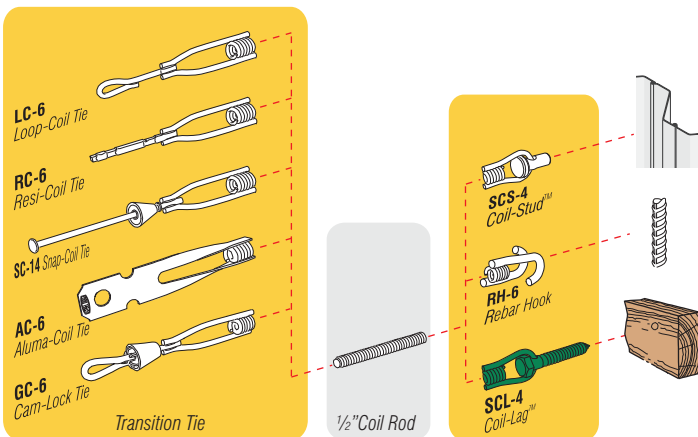

Available From: