

TECHNICAL SPECIFICATIONS

SRD 6' Lightweight Web with Small Hook

6' retractable web, lightweight plastic housing, external shock-absorber, 3/4" double locking snap hook, 1/2" carabiner included. Min breaking strength 3000 lbs. Meets or exceeds ANSI Z359.14-2014. Class A.

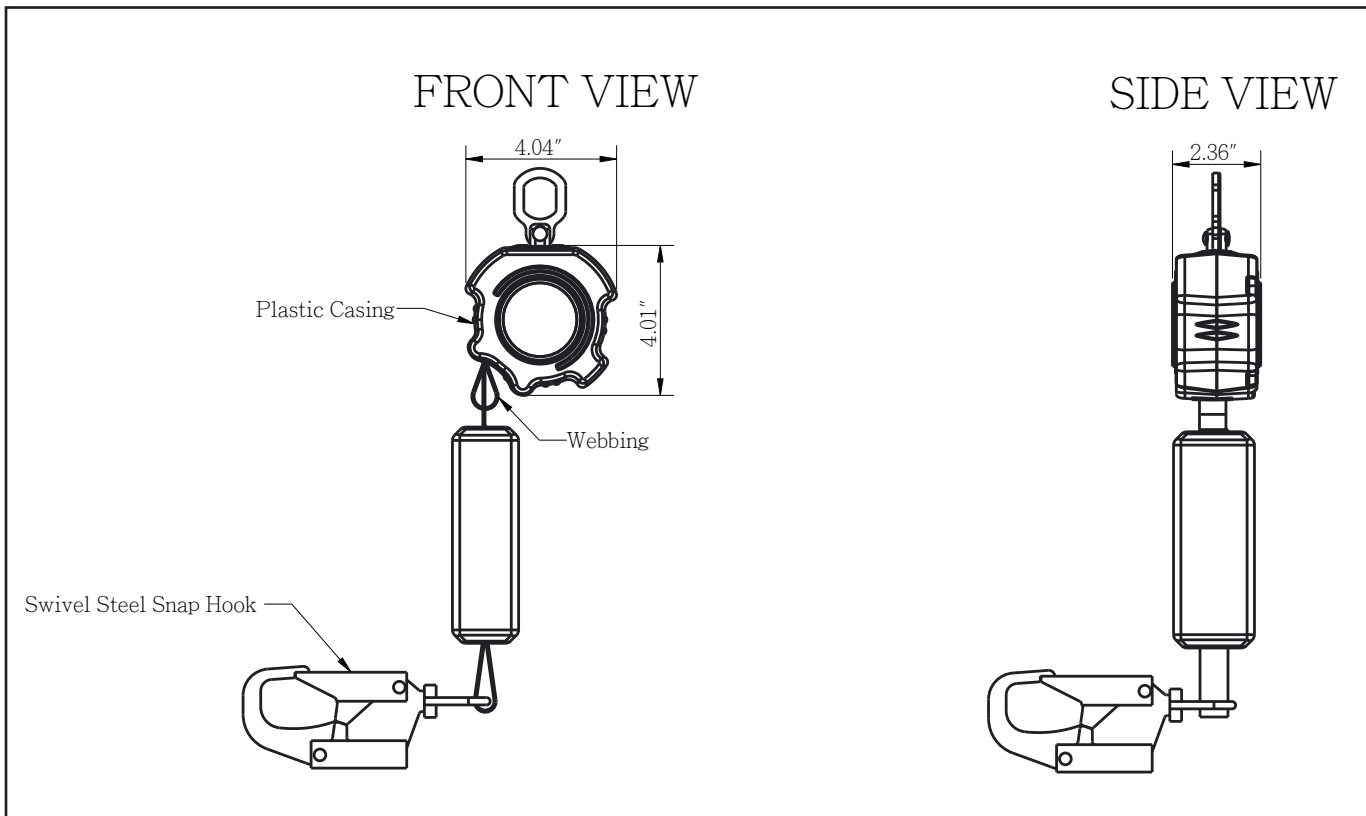

- PHYSICAL PARAMETERS:**
- Lightest available SRD in its range/class.
 - Robust & durable plastic casting.
 - Technora Webbing with Energy absorber.
 - Aluminum quarter turn locking hook at attachment end (as per ANSI Z359.12-2009 gate strength 3600 lbs.)

USER CAPACITY: 420 lbs.

LENGTH: 6 ft. (Maximum)

WEBBING: Material: Technora webbing 13/16"
 Minimum Breaking Strength: 4500 lbs.

VITAL TEST COMPLIANCE:

Static Strength: 3000 lbs. for 1 minute.
 Dynamic Strength: 300 lbs. mass subjected to a 4' free fall. SRD lock and remain lock until released.
 Dynamic Performance: 282 lbs. mass subjected to a zero free fall with extension of 36" webbing. Breaking force less than 1800 lbs. and arrest distance less than 24".

WEIGHT: 1.84 lbs. ± 0.02 lbs.