

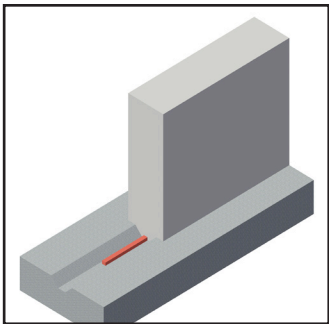

Hydrophilic Waterstop — Bentonite-free

Type NB190®

From the manufacturer of **EARTH SHIELD®**



Earth Shield® Type NB190® (Profile A) is the ideal waterstop for concrete construction joints.

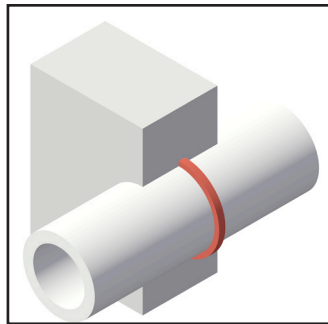

Earth Shield® Type NB190® (Profile A) can be used for pipe or column joints.

Type NB190® is a modern, hydrophilic rubber waterstop with unmatched durability and watersealing capabilities. Manufactured NON-BENTONITE, modified chloroprene rubber, Type NB190® more than doubles its original size (400% volume swell) when exposed to water. This expansion creates an effective compression seal within joints of limited to no movement. Type NB190® can expand and reexpand unlimited times with virtually no loss of physical properties. Additionally, Type NB190® has excellent resistance to many chemicals, is heat-resistant, and can be safely used in drinking water.

- Comprised of **NON-BENTONITE**, modified chloroprene rubber
- 100-plus year lifespan
- Simple, low cost installation
- Ideal for retrofit as well as new construction
- Most profiles have a minimum of 231 ft (100 psi) resistance to water head pressure

Typical Applications

- Water treatment plants
- Wastewater treatment
- Pipe penetrations
- Storage tanks
- Slab on grade
- Foundations
- Tunnel segments
- ... And many more

Earth Shield® Chemical Resistant Waterstop
Phone: 800-821-3859; 951-763-7077
Fax: 951-763-7074

www.earthshield.com

Earth Shield® Modified Chloroprene Strip Applied (SA) Waterstop Basic Use

Earth Shield® Modified Chloroprene Strip Applied Waterstop is used as a fluid-tight diaphragm, running along the joint, for water treatment plants, waste water treatment plants, and fluid containment structures. Earth Shield® Modified Chloroprene Strip Applied Waterstops are intended for **non-moving construction joints only**.

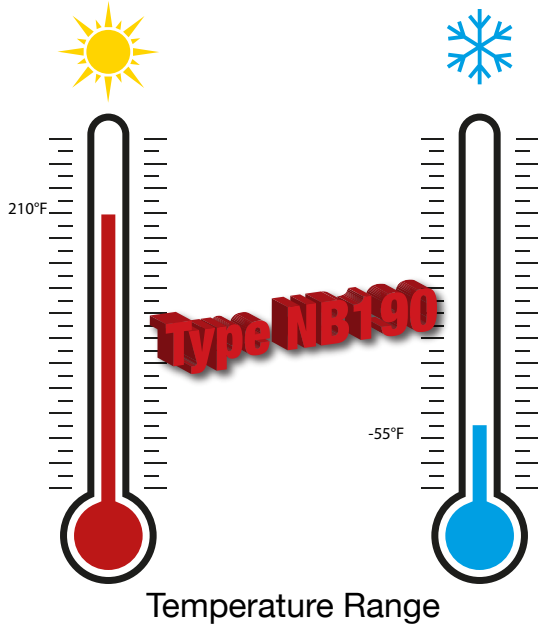

Unlike bentonite-based, strip applied waterstop, Earth Shield® Modified Chloroprene Strip Applied Waterstops do not lose their structural integrity and can expand and reexpand an unlimited number of times without polymer degradation.

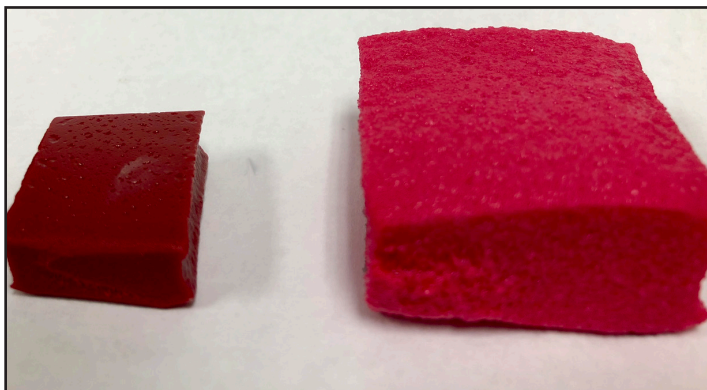

Installation

Install Earth Shield® Modified Chloroprene Strip Applied Waterstops in all non-moving, concrete construction joints. Waterstop should be centered in, and run the extent of the joint. Adhere to concrete using Type NB190® Adhesive. Ensure that minimum concrete clear cover is three inches on all sides of the waterstop (two inches for Profile B).



Specifications

Standard 3-part Specifications are available at our website in Microsoft® Word and Adobe® PDF format. Call our Technical Sales Staff for additional help with your specification.

Suggested Proprietary Short Form Guide Specification Section 03150 (Master Format 2004 – 03 15 13) Earth Shield® Modified Chloroprene Strip Applied Waterstop

Waterstop indicated in drawings and specifications for non-moving construction joints shall be Earth Shield® Modified Chloroprene Strip Applied Waterstop Type NB190® Profile No. #### [Designer insert appropriate profile number here [A, B, or C]] as manufactured by J P Specialties, Inc.; Murrieta, CA 92562; Phone 951-763-7077

1. Earth Shield® Modified Chloroprene Strip Applied Waterstop shall be manufactured from chloroprene and contain no bentonite.
2. Earth Shield® Modified Chloroprene Strip Applied Waterstop shall have a maximum compression set of 45% or under.
3. Minimum concrete cover shall be no less than 3 inches.
4. Adhere to concrete using Type NB190® Adhesive.
5. No equals or substitutions allowed.



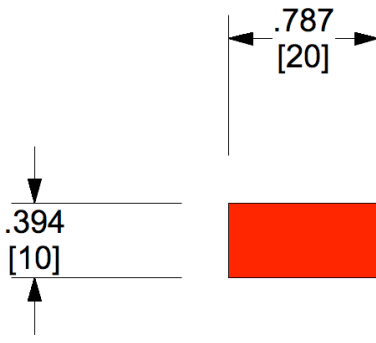

Profile A
For concrete construction joints and pipe penetrations

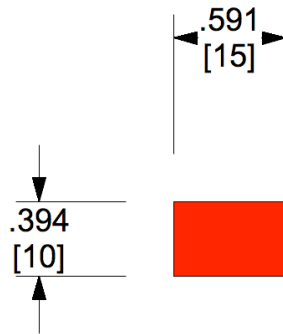

Profile B
For concrete construction joints with minimal concrete clear cover



Profile C
For joint repair and special applications

Unrestrained Hydrophilic Expansion

Fresh Water	24 Hours	115%
Fresh Water	48 Hours	283%
Fresh Water	168 Hours	388%
Fresh Water	852 Hours	400%

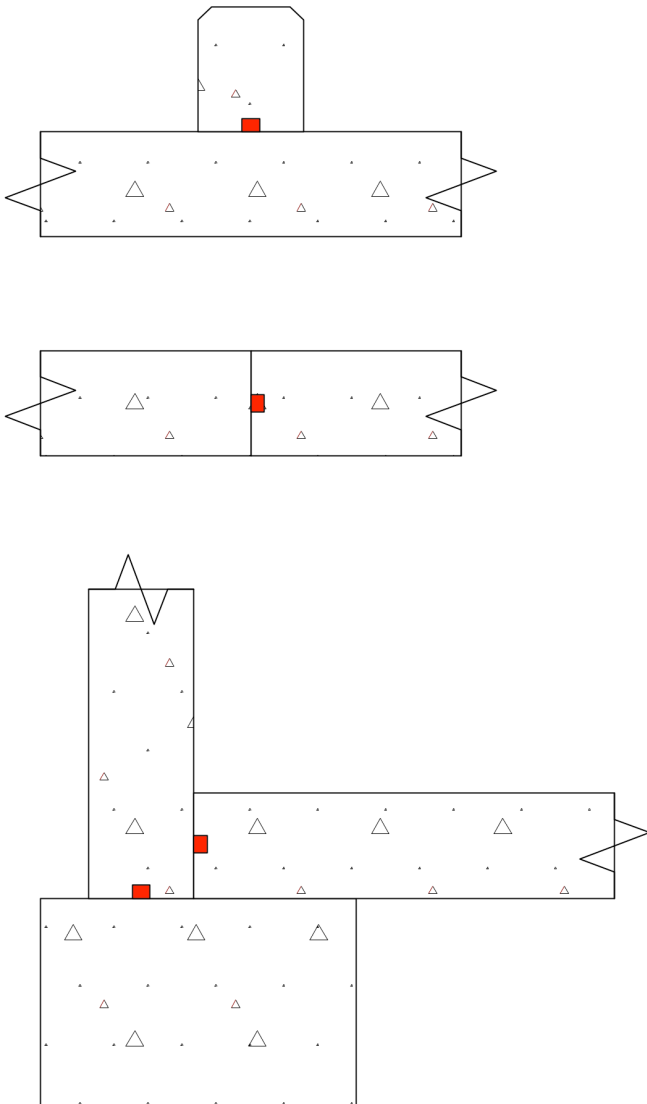
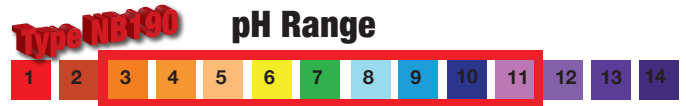

Hydrostatic Pressure Test Results

20 PSI	120 Hours	No leaks
30 PSI	120 Hours	No leaks
50 PSI	120 Hours	No leaks
100 PSI	4,320 Hours	No leaks

Property	Test Method	Required Results
Pressure Resistance		231 ft of Water Head Pressure
Shore A Hardness (5 sec.)	ASTM D2240	36.4 (77°F)
Specific Gravity	ASTM D792	1.46
Tear Strength	ISO 8067	5.56 lb/inch
Compression Set	ASTM D395	45% at 25°C (77°F)
Swelling (fresh water)		400%
Swelling (salt water)		46%
Chemical Resistance	ASTM D471	Meet or exceed specific testing standards for contained fluids as required by Owner and certified by Manufacturer

Contact the "Waterstop Experts" at 951-763-7077

Availability

National and International Warehouses

Earth Shield® Modified Chloroprene Strip Applied Waterstop is readily available from a variety of sources:

- **Preferred Regional Stocking Partners** — *We are partners with some of the very best Concrete Accessories Distributors in the world. All our preferred partners have large stocking inventories and are factory trained to provide the utmost in on-site assistance.*
- **Distributor Sales** — *Earth Shield® can be special ordered from many distributor sales channels throughout the world.*
- **Factory Direct** — *Earth Shield® may be contacted directly for project quotation and product purchase (call 800-821-3859).*

Services

- *Project and Product Certification* — *We assist the Design Engineer and Project Owner with individual project and product certification. When you specify our waterstop, you can be assured it is the correct product for your application.*
- *Take-off Assistance* — *For the Contractor.*
- *Shop Drawings* — *3-D isometric and 2-D CAD details are available to assist the project.*
- *On-site waterstop installation assistance* — *\$1,000.00 per day*
- *Telephone and Web-based assistance* — *Always FREE*

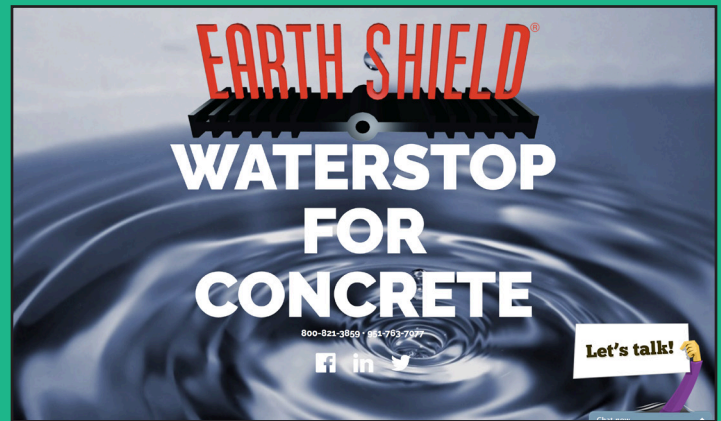

Visit Earth Shield® on the Web at
www.earthshield.com

Earth Shield® Waterstop Limited Warranty

J P Specialties, Inc. warrants to the Buyer that this product is new and will be free from defects and will perform as represented in writing subject to the two (2) following conditions: First, the application of the product and the concrete construction practices used in the application are in accordance with J P Specialties, Inc. recommendations; and, Second, the Buyer has selected the proper product for the specific application required.

Any information supplied in good faith by J P Specialties, Inc. with respect to its products is believed to be correct. J P Specialties, Inc. Makes no representation or warranties, expressed or implied, as to the accuracy or completeness of such information.

The exclusive remedies of the Buyer and the limit of the liability of J P Specialties, Inc. from any and all losses or damages resulting from the use of this product shall be either full refund of the purchase price to the Buyer of this product or the replacement of the quantity of product purchased by the Buyer at the discretion of J P Specialties, Inc.

All supplied testing data has been performed by independent testing laboratories.

Distributed by:

Earth Shield® Chemical Resistant Waterstop
Phone: 800-821-3859; 951-763-7077
Fax: 951-763-7074

www.earthshield.com



 www.facebook.com/waterstop